



WORK HOLDING & TOOL HOLDING



STD and StandardFLEX VISE

GERARDI FOCUS



ENGLISH VERSION



MULTITASKING VISE



FMS VISE



MULTITASKING VISE



ZERO POINT



TOMBSTONES / PALLETS / BASE PLATES



CLASSIC LINE ANGLE HEADS



EVOLUTION ANGLE HEADS

WWW.GERARDI.IT

DISCOVER OTHER PRODUCTS INSIDE!!

THE HISTORY

The first Italian company to design and develop a complete steel modular workholding system which Guaranteed international worldwide success!



1971 Gerardi S.p.A. Co. has been established by Ivano Gerardi Sr. in 1971. Located just 5 km off from Malpensa airport of Milan, Gerardi company quickly grew as the largest Italian vise manufacturer and workholding solutions. It is one of the leaders in the European Common Market and the quality of its products and solutions are well-known and appreciated worldwide.

1980 Starting from 1986, Gerardi S.p.A. has designed a wide range of Angle Heads for traditional machine tools/machining centers and Driven Tools for C.N.C. lathes. The best markets of these products are nowadays those where the automotive and the aeronautic are more developed. In the eighties the company also developed its own Grinding machines with a totally new concept at the base of the project.

1990 The company established a joint-venture in China for the manufacture of parts and types of vises together with the Chinese aerospace industry. Thanks to major investments the new company is today fully controlled by Gerardi and it is achieving the same excellent leadership results in Asia and worldwide as those accomplished in Europe.

2000 After the set up of a US subsidiary Co. near Chicago (Huntley - IL), new German and English branches have been established in Stuttgart / Germany in 2007 and in Bristol / UK in 2010 in order to better penetrate and serve the local markets. Of course this meant a huge financial effort and investment but the fast evolution and continuous adjustments to high competitive markets has always been the main Gerardi S.p.A. feature.

2012 Gerardi sets up a new plant for angle heads manufacturing in LONATE POZZOLO and a new company in INDIA for the manufacturing of fixtures for the Indian market.

2015 The Gerardi S.p.A. Co. staff today counts over 200 employees, with an average age of under 40. All the top roles and manager positions of the company have been acquired through internal training and experience geared towards the development of individual skills and abilities. Our total export in more than 50 countries around the world is today more than 70% of our total production and we invest about 10% of our total turnover in advanced technological research for new products.

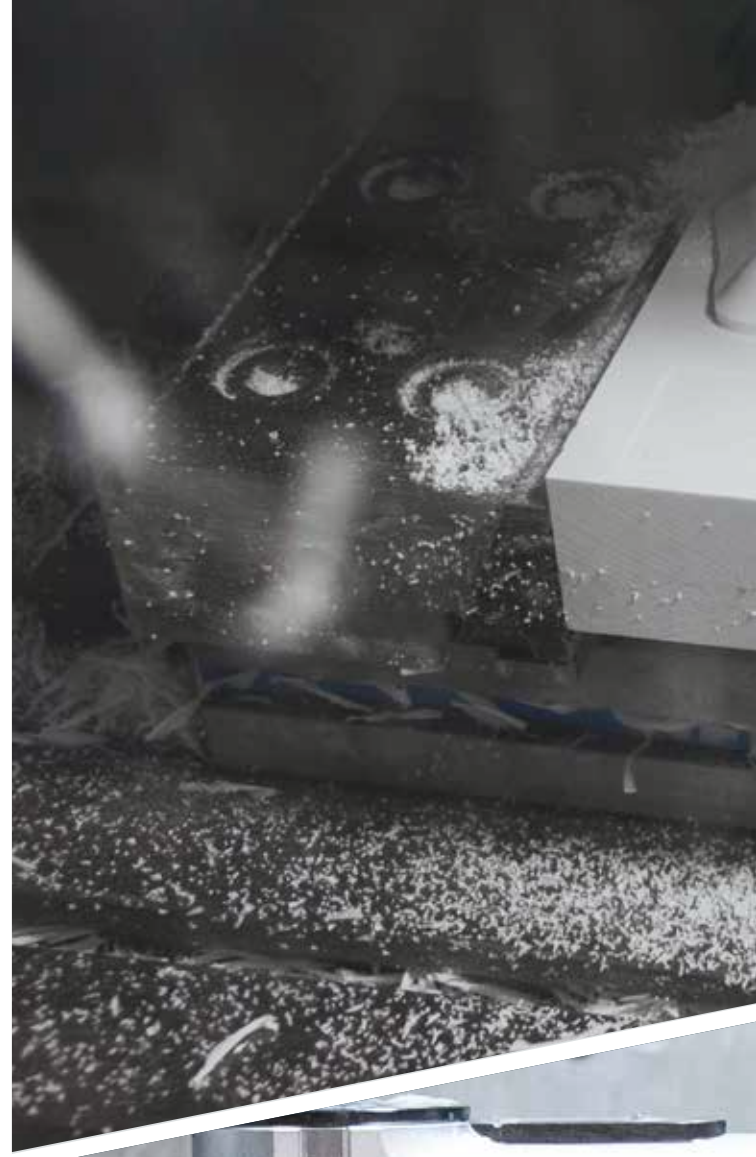



COMPACT, RIGID and ACCURATE



Compact Grip Reversible jaws

Art. 645T - G15
GRIP - Pitch 1,5mm



Art. 645T - G02
GRIP - Pitch 2mm



Art. 645T - G11
GRIP - Pitch 11mm



Art. 645T - IST
Smooth treated jaw



Art. 645T
Dove tail jaw



Vise Size	1			2				3				
Jaw Width W	50			86				118				
Max Opening A	6			96	136	176	216	126	176	226	276	326
Vise Height	65			65				89				
Base Height	45			38				57				
Base Width	80			90				126				
Base Length	80	120	160	120	160	200	240	160	210	260	310	360
Pull Stud Pitches	52			52				96				

Compact Grip Vises

ORDER CODES	7.65.01080	7.65.01120	7.65.01160	7.65.02120	7.65.02160	7.65.02200	7.65.02240	7.65.03160	7.65.03210	7.65.03260	7.65.03310	7.65.03360
-------------	------------	------------	------------	------------	------------	------------	------------	------------	------------	------------	------------	------------

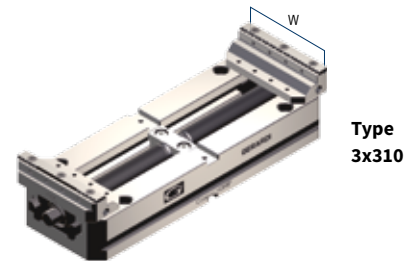
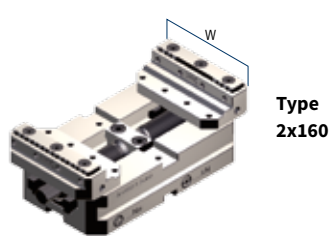
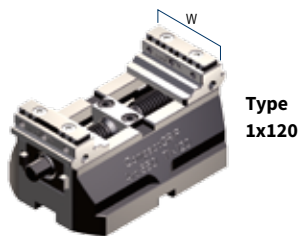

NEW OKUMA DRIVEN TOOLS

OKUMA

BMT 60 - Multus U3000 / Multus U4000 / Genos L300 MW + MYW (Radial) / LB 2000 / LB 2500 / LB3000EX (MW) / LB2000EX / LB2500 / LB3000EX (M) / LU3000 M / LU3000 MY

Axial

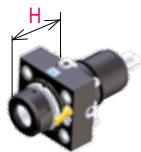

BMT	Coolant	ER	H	Nm	Rpm	ORDER CODE
60	Ext.	32	78	60	6000	99.OK.A80
60	Int/Ext	32	70	60	6000	99.OK.A81

Radial*

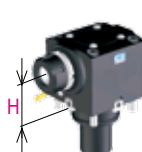

BMT	Coolant	ER	H	Nm	Rpm	ORDER CODE
60	Ext.	32	78	60	6000	99.OK.A82
60	Int/Ext	32	70	60	6000	99.OK.A83

*Direction of rotation opposite to machine spindle

CLASSIC LINE

NEW!





LIGHT SERIES of AUTOMATIC TOOL CHANGE



*Min bore for internal machining.
Excludes cutting tool

Type 0 (Ø73) - * Type 1 (Ø90)

Model	Output	L	Ø min*	Rpm	Nm	ORDER CODE
 GL90-7	ER11 Ø1/7	107	65	6.000	5	9.GL9.07000
 GL90L-10	ER16 Ø1/10	87	87	6.000	10	9.GL9.10000
 * GL90L-16	*ER25 Ø1/16	82	130	4.000	24	9.GL9.16000



► DESIGN

Design studied for the best PRICE - QUALITY ratio



► ALUMINUM BODY

Angle heads with ALLUMINUM body. Weight reduction with same performances and rigidity on compact high speed machining centres



► CONIC positioning pin

New CONIC positioning pin ideal for compact and high speed machining centres
- Allows a quick and safe tool change
- Help to absorb vibrations.

IDEAL for COMPACT AND HIGH SPEED MACHINING CENTRES FANUC / BROTHER / JINGDIAO / MECTRON

EVOLUTION LINE

NEW!



LIGHT SERIES of AUTOMATIC TOOL CHANGE

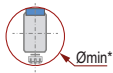

*Min bore for internal machining.
Excludes cutting tool

Model	Output	L	Ø min*	Rpm	Nm	ORDER CODE
 FL90-7	ER11 -Ø1/7	52	Ø77	8.000	5	9.FL9.07000
 FL90L-13	ER20 -Ø1-13	76	Ø122	6.000	20	9.FL9.13000
 FL90L-16	ER25 -Ø1-16	76	Ø124	4.000	26	9.FL9.16000



► DESIGN

Design studied for the best PRICE - QUALITY ratio



► ALUMINUM BODY

Angle heads with ALLUMINUM body. Weight reduction with same performances and rigidity on compact high speed machining centres



► Custom STOP BLOCK

Custom made stop-block for FANUC / BROTHER / JINGDIAO / MECTRON and all compact high speed machining centres.



► CONIC positioning pin

New CONIC positioning pin ideal for compact and high speed machining centres
- Allows a quick and safe tool change
- Help to absorb vibrations.

IDEAL for COMPACT AND HIGH SPEED MACHINING CENTRES FANUC / BROTHER / JINGDIAO / MECTRON



Supplied with Gerardi StandardFLEX Machine Vise:

- 1x workstop ART.370
- 1x pair of positioning keys (16mm)
- 1x box wrench ART.375
- 1x T wrench ART.376
- 4x table clamps (6 with XL vise)



MADE IN ITALY

1	MODULAR	The world's largest range of modular accessories means clamping almost ANYTHING is possible with Gerardi's standard jaws.
2	NO WEAR	Made 100% from high quality, case hardened HRC 60 alloyed resistance steel in order to give maximum rigidity, high performance and no wear. As evidence we give 5 YEARS WARRANTY on all the vises and mechanical components.
3	QUICK CLAMPING	Sliding movable jaw is pushed close to the work piece then fully tightened with 1/4 turn of the wrench. Also available with Hydraulic, Pneumatic, Manual hydraulic & Electrical hydraulic clamping.
4	HIGHEST ACCURACY +/-0.02mm	Every sliding and working surface is ground. Centesimal tolerances are guaranteed by checking cycles with CNC measuring machine. The perfect alignment with the machine axis is given by longitudinal and cross keyways (16H7)
5	QUICK HAND CHANGE JAWS	ONLY with Gerardi Standard Flex vises is it possible to change the vise jaw plates in under 5 seconds. The special comb design ensures jaw plates glide into place. All working surfaces are ground and hardened to HRC60 as standard on jaw plates.
6	BETTER PULL DOWN ACTION	Increased and better pull down straight action and better protection from chips. The vise can be used WITH or WITHOUT pull down action.

Endless Clamping Possibilities!

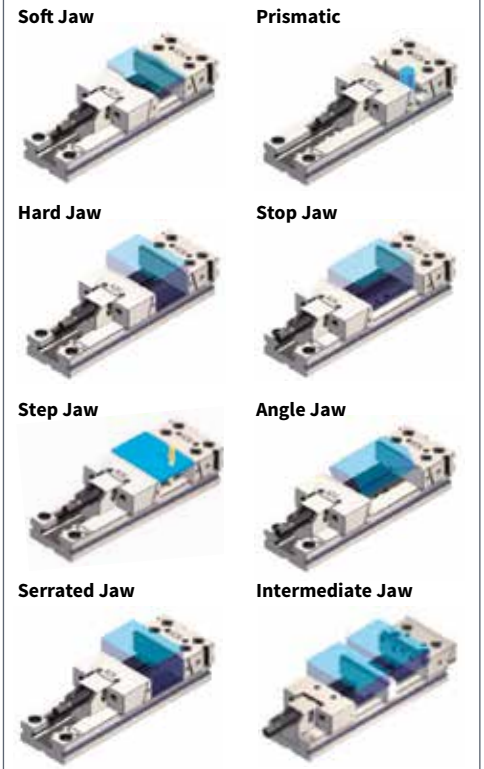

Standard Flex Vises - Art.1A

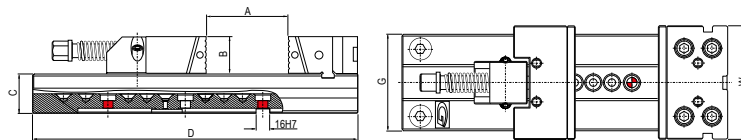

	SIZE								
	2 (25kN)		3 (30kN)		4 (30kN)		5 (40kN)		
A	150	200	300	200	300	400	200	300	400
W	121	146			171			196	
B	40	50			60			65	
C	40	50			58			70	
D	345	420	520	455	555	655	495	595	695
G	95	125			145			170	
kg	13.2	26.2	29.7	37.9	43	48.1	65.3	70.3	75.3
ART.1A ORDER CODES	1.1A.20000	1.1A.32000	1.1A.33000	1.1A.42000	1.1A.43000	1.1A.44000	1.1A.52000	1.1A.53000	1.1A.54000

Standard Flex XL Single Vises - Art.20A

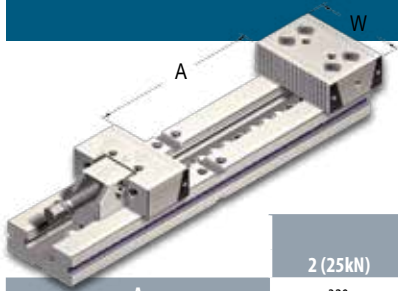

ADD 1 MOVABLE JAW TO TURN INTO A DOUBLE XL Vise



	SIZE								
	2 (25kN)	3 (30kN)		4 (30kN)			5 (40kN)		
A	320	360	460	400	500	600	600	700	900
W	121	149		171			196		
B	38	48		58			63		
C	40	50		58			70		
D	520	580	680	666	766	866	905	1005	1205
G	95	125		145			170		
kg	12.9	25.5	29	37	42	47	69	74	84
ART.20A ORDER CODES	2.20.A2320	2.20.A3360	2.20.A3460	2.20.A4400	2.20.A44500	2.20.A4600	2.20.A5600	2.20.A5700	2.20.A5900

Standard Flex XL Double Vises - Art.30A

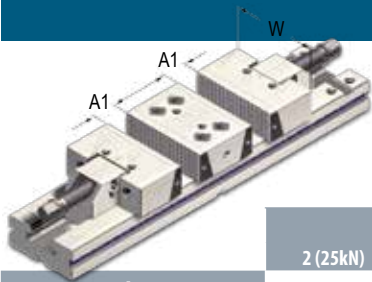

REMOVE 1 MOVABLE JAW TO TURN INTO A SINGLE XL Vise



	SIZE								
	2 (25kN)	3 (30kN)		4 (30kN)			5 (40kN)		
A1	2x100	2x110	2x160	2x120	2x170	2x220	2x200	2x250	2x350
W	121	146		171			196		
B	38	48		58			63		
C	40	50		58			70		
D	520	580	680	666	766	866	905	1005	1205
G	95	125		145			170		
kg	12.9	25.5	29	37	42	47	69	74	84
ART.30A ORDER CODES	2.30.A2100	2.30.A3110	2.30.A3160	2.30.A4120	2.30.A4170	2.30.A4220	2.30.A5200	2.30.A5250	2.30.A5350

Jaw Plates

	ART.	Vise SIZE (W)				
		2 (121)	3 (146)	4 (171)	5 (196)	
Soft		ART.230B	4.23.0B201	4.23.0B301	4.23.0B401	4.23.0B501
Hard Smooth		ART.230C	4.23.0C201	4.23.0C301	4.23.0C401	4.23.0C501
Step		ART.230E	4.23.0E201	4.23.0E301	4.23.0E401	4.23.0E501
Prismatic		ART.230F	4.23.0F201	4.23.0F301	4.23.0F401	4.23.0F501
Angle		ART.230M	4.23.0M201-45	4.23.0M301-45	4.23.0M401-45	4.23.0M501-45
Intermediate Jaw with Step		ART.212	22000	1.21.23000	1.21.24000	1.21.25000

Step Jaw Plates Sets With Rack - Art.230E

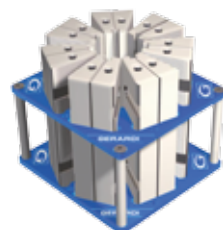
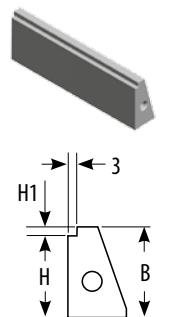

	Vise SIZE (W)			
	2 (121)	3 (146)	4 (171)	5 (196)
H	33	43	53	53
B	38	48	58	63
Step Jaws Included In The Set	3 x2	3 x2	3 x2	3 x2
	5 x2	5 x2	5 x2	5 x2
	10 x2	10 x2	10 x2	10 x2
	13 x2	13 x2	13 x2	13 x2
	18 x2	18 x2	18 x2	18 x2
	23 x2	23 x2	23 x2	23 x2
	-	28 x2	28 x2	28 x2
ORDER CODE	4.32.0A200	4.32.0A300	4.32.0A400	4.32.0A500



MADE IN ITALY

1	MODULAR	The world's largest range of modular accessories means clamping almost ANYTHING is possible with Gerardi's standard jaws.
2	NO WEAR	Made 100% from high quality, case hardened HRC 60 alloyed resistance steel in order to give maximum rigidity, high performance and no wear. As evidence we give 5 YEARS WARRANTY on all the vises and mechanical components.
3	QUICK CLAMPING	Sliding movable jaw is pushed close to the work piece then fully tightened with 1/4 turn of the wrench. NO WINDING! Also available with Hydraulic, Pneumatic, Manual hydraulic & Electrical hydraulic clamping.
4	HIGHEST ACCURACY +/-0.02mm	Every sliding and working surface is ground. Centesimal tolerances are guaranteed by checking cycles with CNC measuring machine. The perfect alignment with the machine axis is given by longitudinal and cross keyways (16H7)
5	'ON/OFF' PULL DOWN JAWS	ONLY with Gerardi Standard Series vises is it possible to change from pull down action to non-pull down action. By turning the screw 1/4 turn in the rear of the jaw, the pull-down action can be turned on or off.
6	5mm STEP ON FIXED JAW	The fixed jaw is supplied as standard with a 5mm step on the rear. Reverse the jaw and combine with ART.217 (Prismatic Jaw with Step) for through hole drilling/tapping operations.

Supplied with Gerardi Standard Series Machine Vise:

- 1x workstop ART.370
- 1x pair of positioning keys (16mm)
- 1x box wrench ART.375
- 1x T wrench ART.376
- 4x table clamps (6 with XL vise)

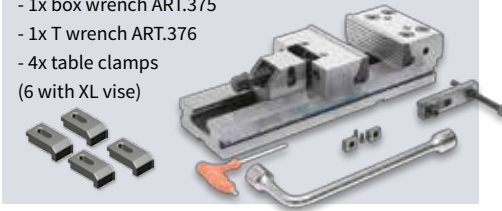

Endless Clamping Possibilities!

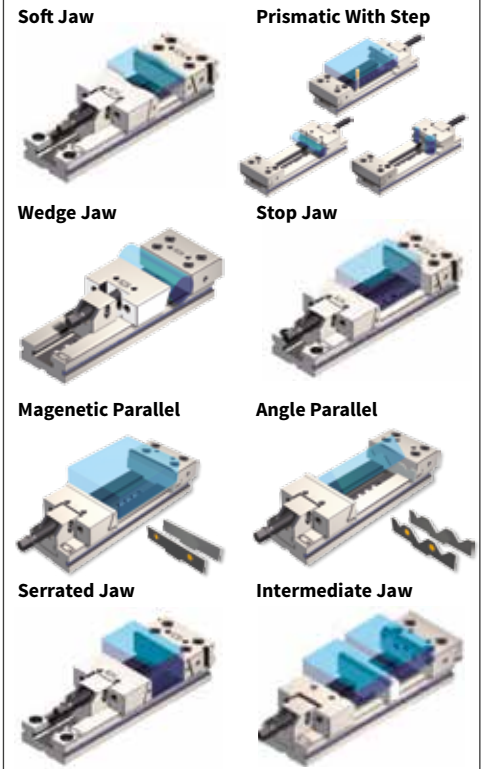

Standard Series Vises - Art. 1

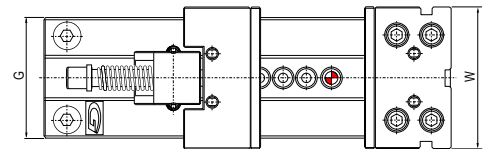
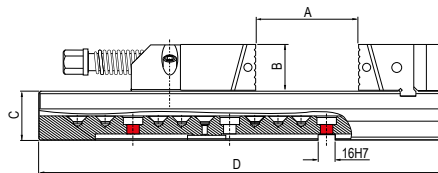

	SIZE								
	2 (25kN)		3 (30kN)		4 (30kN)			5 (40kN)	
A	150	200	300	200	300	400	300	400	500
W	125	150			175		200		
B	40	50			60		65		
C	40	50			58		70		
D	345	420	520	455	555	655	595	695	795
G	95	125			145		170		
kg	12.9	25.5	29	37	42	47	69	74	79
ART. 1A ORDER CODES	3.02.10000	3.03.20000	3.03.30000	3.04.20000	3.04.30000	3.04.40000	3.05.30000	3.05.40000	3.05.50000

Pull down jaws with consistent clamping & powerful clamping pressure - no need for a hydraulic vise!



Standard Series XL Single Vises - Art.21

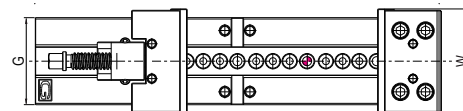
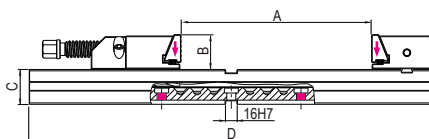

	SIZE								
	2 (25kN)	3 (30kN)			4 (30kN)			5 (40kN)	
A	320	360	450	400	500	600	600	700	800
W	125	150			175			200	
B	40	50			60			65	
C	40	50			58			70	
D	520	580	680	666	766	866	905	1005	1105
G	95	125			145			170	
kg	17	32	35	47	52	56	69	74	79
ART.20 ORDER CODES	2.21.23200	2.21.33600	2.21.34600	2.21.44000	2.21.45000	2.21.46000	2.21.56000	2.21.57000	2.21.58000

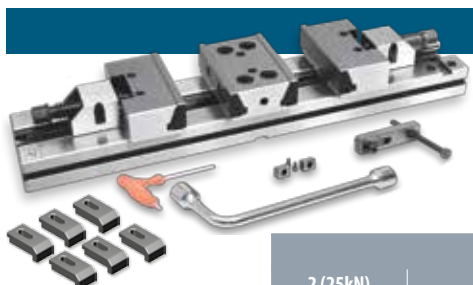

Standard Series XL Double Vises - Art.30

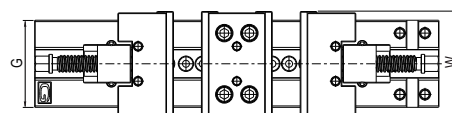
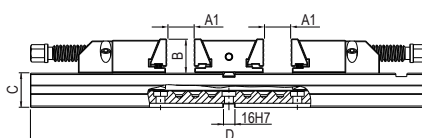

	SIZE								
	2 (25kN)	3 (30kN)			4 (30kN)			5 (40kN)	
A1	2 x 100	2 x 110	2 x 160	2 x 120	2 x 170	2 x 220	2 x 200	2 x 250	2 x 300
W	125	150			175			200	
B	40	50			60			65	
C	40	50			58			70	
D	520	580	680	666	766	866	905	1005	1105
G	95	125			145			170	
kg	21	39	43	59	64	69	102	108	114
ART.30 ORDER CODES	3.32.10600	3.33.20600	3.33.30600	3.34.20600	3.34.30600	3.34.40600	3.35.30600	3.35.40600	3.35.50600

Jaws & Jaw Plates

	ART.	VISE SIZE (W)			
		2 (125)	3 (150)	4 (175)	5 (200)
Soft	ART.165	1.65.20000	1.65.30000	1.65.40000	1.65.50000
Hard Smooth	ART.232	1.65.20100	1.65.30100	1.65.40100	1.65.50100
Wedge Jaw	ART.210	2.21.02000	2.21.03000	2.21.04000	2.21.05000
Prismatic Jaw With Step	ART.217	2.21.72000	2.21.73000	2.21.74000	2.21.75000
Angle Plate	ART.314	4.31.42000-45	4.31.43000-45	4.31.44000-45	4.31.45000-45
Intermediate Jaw with Step	ART.212	1.21.22000	1.21.23000	1.21.24000	1.21.25000

Magnetic Parallel Plates - Art.313 (1 Pair)

	Vise SIZE (W)			
	2 (125)	3 (150)	4 (175)	5 (200)
Width	125	150	175	200
Height	35	45	55	57
ORDER CODE	4.31.32000-35	4.31.33000-45	4.31.34000-55	4.31.35000-57

Magnetic Parallel Plate Sets* - Art.310 (6 Pairs)

	Vise SIZE (W)			
	2 (125)	3 (150)	4 (175)	5 (200)
Width	125	150	175	200
Parallel Plates (Height) Included In The Set *Rack not included	15	25	35	35
	20	30	40	40
	25	35	45	45
	30	40	50	50
	35	45	55	57
	37	47	57	60
ORDER CODE PLATE SET	4.31.02000	4.31.03000	4.31.04000	4.31.05000
ORDER CODE RACK	4.31.71000			

Gerardi modular elements allow perfect clamping of big workpieces which need the heaviest machining using the machine table as surface.

Modular Elements are a solution for a wide range of applications and, with the many reference points available, it is a perfect complement or alternative to single or double vises.

- No Wear - 100% HRC60 Hardened Steel
- Quick Clamping
- Modularity & Versatility
- Highest Accuracies ± 0.02 mm
- Rigidity & Safety
- Space Saving Design



MADE IN ITALY

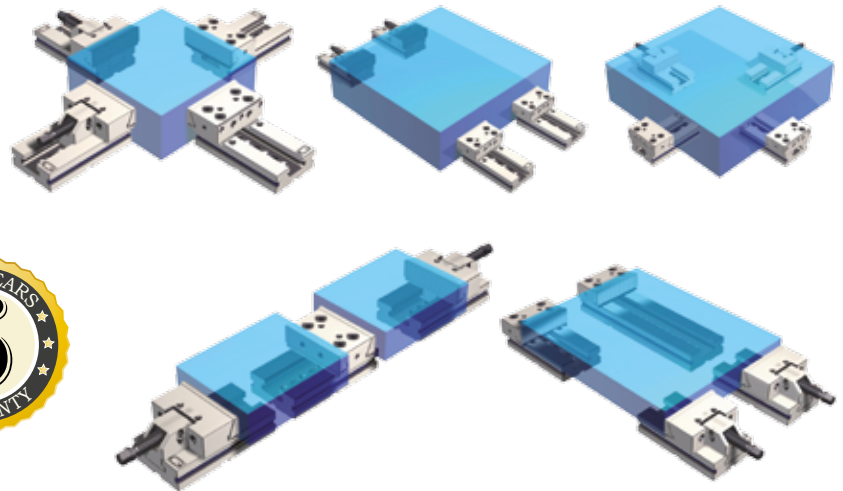

Movable Jaw Section & Base - Art.102

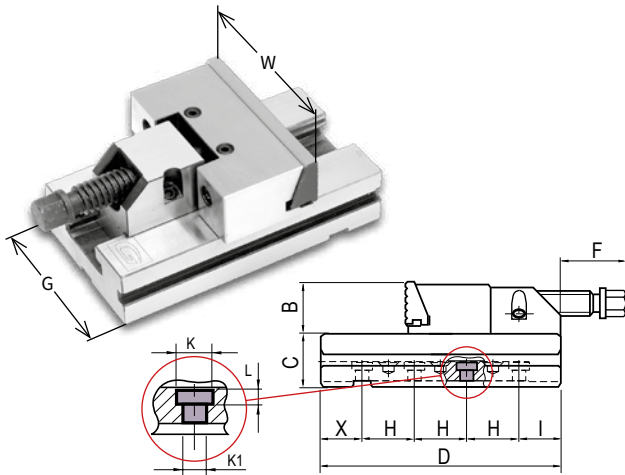

	1	2	3	4	5	6
W	100	125	150	175	200	300
B	30	40	50	60	65	80
C	35	40	50	58	70	78
D	140	160	230	240	300	350
F	55	83	82	62	92	70
G	75	95	125	145	170	195
H	40	40	50	50	100	100
I	29	39	40	82.5	69	83
L	4.5	5.5	8.5	8.5	17	17
kg	3.4	6.3	14.2	20.8	35	60
ORDER CODE	2.10.21000	2.10.22000	2.10.23000	2.10.24000	2.10.25000	2.10.26000

Fixed Jaw Section & Base - Art.103

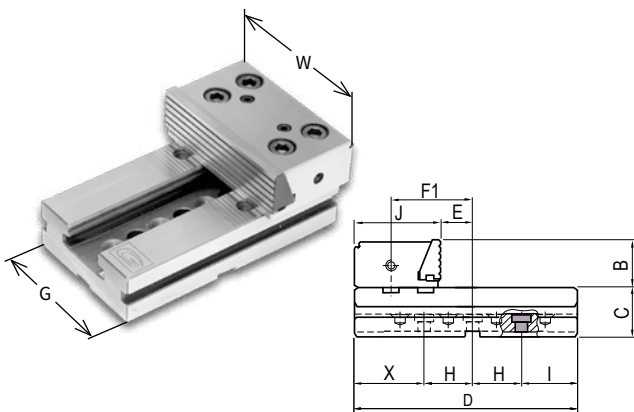

W, G, B, C & D are as the table above
*M = Number of Holes

	1	2	3	4	5	6
J	77.9	77.9	89.4	96.9	113.4	120.4
E	33.6	33.6	33.6	33.6	33.6	33.6
F1	76	76	84.5	89	100	107
X	31	31	72.5	29	45	52
H	40	40	50	50	100	100
I	29	49	57.5	61	55	98
kg	3.3	5.8	12.6	17.8	29.8	50.5
M*	3	3	3	4	5	5
ORDER CODE	2.10.31000	2.10.32000	2.10.33000	2.10.34000	2.10.35000	2.10.36000

Double Fixed Jaw Section & Base - Art.104

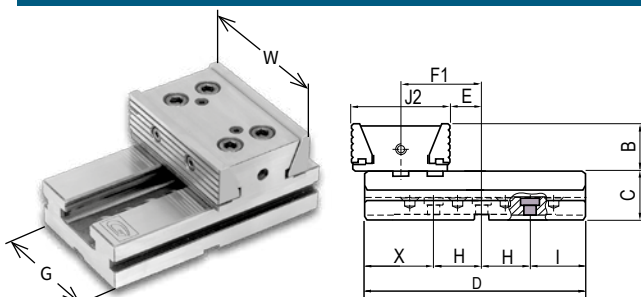

W, G, B, C, D, F1, X, H & I are as the tables above
*M = Number of Holes

	1	2	3	4	5	6
J2	84.8	84.8	101.8	110.8	132.8	146.8
E	33.6	33.6	33.6	33.6	33.6	33.6
kg	3.4	6	13.3	18.8	30	52.5
M*	3	3	3	4	5	5
ORDER CODE	2.10.41000	2.10.42000	2.10.43000	2.10.44000	2.10.45000	2.10.46000

Grinding, Inspection & EDM - Art.666 & Art.666S

- **ART.666** 100% case hardened steel HRC 60 for grinding & inspection
- **ART.666S** X4 CR14 corrosion resistant steel for EDM
- Squareness and parallelism: 0,003 mm / 100 mm
- Supplied with 4 clamping jaws, 1 fixed work stop & 1 movable workstop



SIZE	0	1	2	3	4	5	6	7	8
kN			160 kN	160 kN	180 kN	180 kN	180 kN	180 kN	200 kN
A	27	80	100	120	160	180	200	260	200
W	30	60	75	100	125	125	125	125	160
B	15	28	40	45	50	50	50	50	63
C	15	28	35	42	50	50	50	50	63
D	75	175	220	260	330	350	370	430	410
E	15	40	50	55	65	65	65	65	80
F	33	55	50	85	105	105	105	110	130
kg	0.28	2.820	5.820	10.740	19.450	20.080	20.720	26.720	38

HRC60 STEEL FOR GRINDING & INSPECTION - ART.666

ORDER CODE	3.66.60000	3.66.61000	3.66.62000	3.66.63000	3.66.64000	3.66.65000	3.66.66000	3.66.67000	3.66.68000
------------	------------	------------	------------	------------	------------	------------	------------	------------	------------

X4 CR14 CORROSION RESISTANT STEEL FOR EDM - ART.666S

ORDER CODE	3.66.65000	3.66.65100	3.66.65200	3.66.65300	3.66.65400	3.66.65500	3.66.65600	3.66.65700	3.66.65800
------------	------------	------------	------------	------------	------------	------------	------------	------------	------------

Sine Vise 0-90° - Art.667

- All case hardened and hardened HRC 60 steel all case hardened and hardened HRC 60 steel
- Squareness and parallelism: 0,003 mm / 100 mm
- Ideal for grinding E.D.M. machine and for milling operations also for checking and control

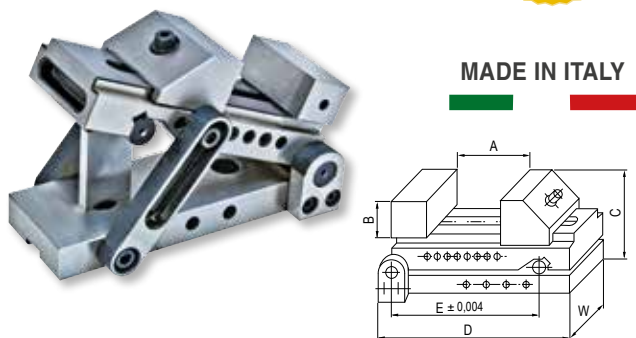

SIZE	1	2	3
A	100	120	160
W	75	100	125
B	32	45	50
C	95	116	139
D	214	244	303,5
E	150	200	240
kg	9	15	26
ORDER CODE	1.66.71000	1.66.72000	1.66.73000

Stainless Steel Vise - Art.668

MADE IN ITALY

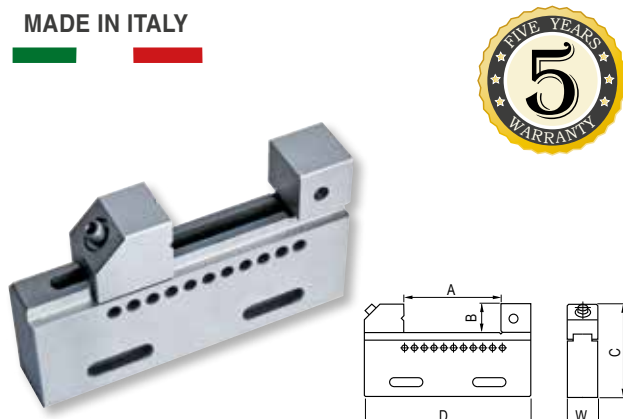

SIZE	1	2	3
A	100	150	214
W	32	32	36
B	30	35	40
C	95	100	110
D	170	226	300
kg	4	5	6
ORDER CODE	1.66.81000	1.66.82000	1.66.83000

Available as vise tower for vertical use or standard vise for horizontal use on VMC

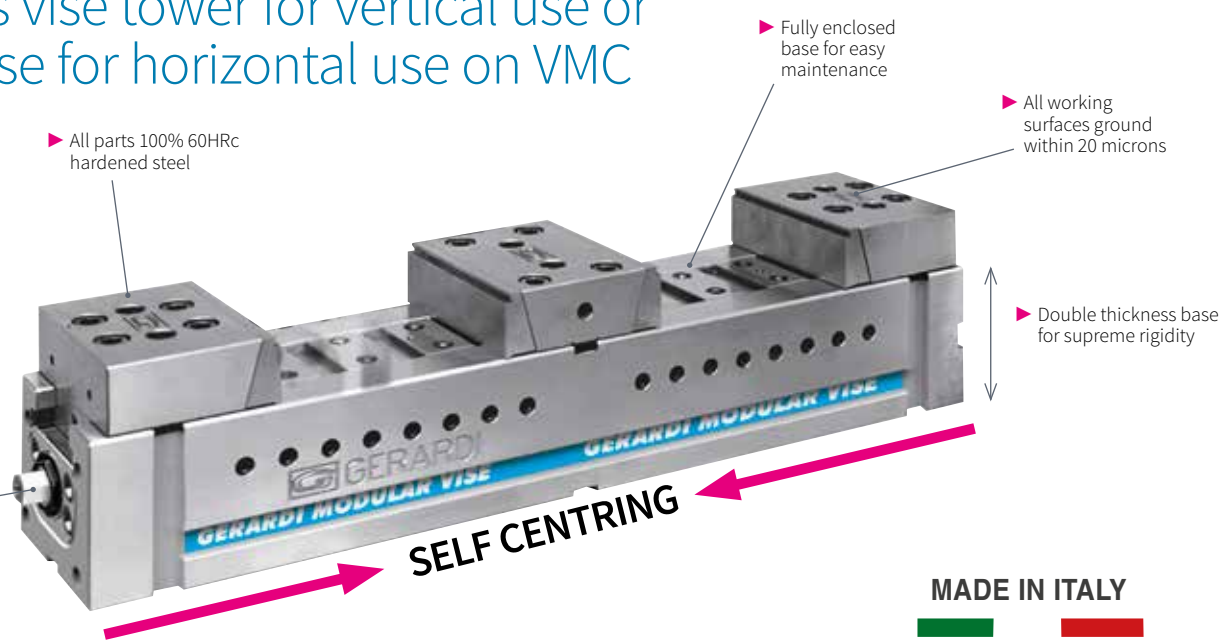

MADE IN ITALY

FMS Vises: Double, Single & Self Centring

Vise Size & Clamping Force	2 25kN			3 30kN		4 30kN
Base Height	90	90	90	100	100	120
Base Width	95	95	95	125	125	145
Base Length	400	500	600	500	600	600

Standard Configuration

Art 863 Double with step jaws						
ORDER CODE Art 863	5.86.32400	5.86.32500	5.86.32600	5.86.33500	5.86.33600	5.86.34600

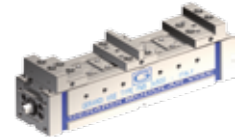

Art 860 Double with straight jaws						
ORDER CODE Art 860	5.86.02400	5.86.02500	5.86.02600	5.86.03500	5.86.03600	5.86.04600



Art 865 Quick hand change pull down jaws						
ORDER CODE Art 865	5.86.52400	5.86.52500	5.86.52600	5.86.53500	5.86.53600	5.86.54600



Art 866 Double with floating jaws						
ORDER CODE Art 866	5.86.62400	5.86.62500	5.86.62600	5.86.63500	5.86.63600	5.86.64600

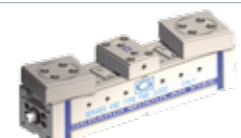

Art 867 Double with floating jaws for plates						
ORDER CODE Art 867	5.86.72400	5.86.72500	5.86.72600	5.86.73500	5.86.73600	5.86.74600

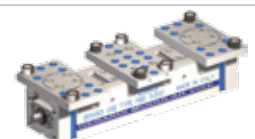



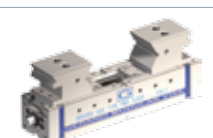

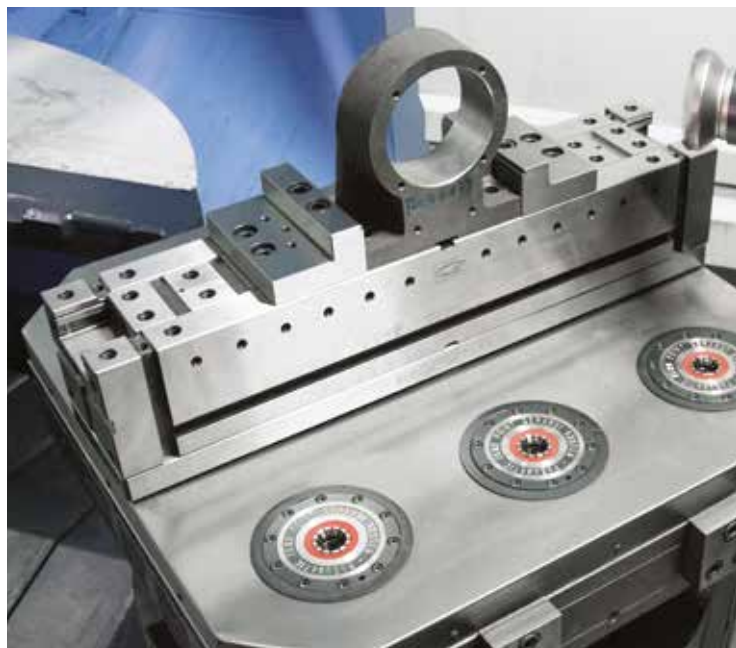
Art 870 Single with prismatic jaws						
ORDER CODE Art 870	5.87.02400	5.87.02500	5.87.02600	5.87.03500	5.87.03600	5.87.04600





FMS Accessories

		Vise SIZE (W)		
		2 (95)	3 (125)	4 (145)
Standard Base Plate				
	ART.827	5.82.72000	5.82.73000	5.82.74000
Square Support				
	ART.836	5.83.62000	5.83.63000	5.83.64000
Torque Multiplier				
	ART.802	5.80.22000	5.80.23000	5.80.24000
Hydraulic Motor				
	ART.890	5.89.02000	5.89.03000	5.89.04000

Application Ideas/Extra Offers:
(additional jaws may be required)









GET A FIXED INTERMEDIATE JAW FOR **FREE** WITH ART 863

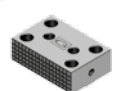

GET 4 QUICK HAND CHANGE JAW PLATES FOR **FREE** WITH ART 865

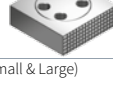

FMS Jaws

		Vise SIZE (W)		
		2 (95)	3 (125)	4 (145)
Serrated				
	ART.805	5.80.52000	5.80.53000	5.80.54000
Smooth Hard				
	ART.805A	5.80.5A200	5.80.5A300	5.80.5A400
Soft				
	ART.805B	5.80.5B200	5.80.5B300	5.80.5B400
Prismatic Vertical				
	ART.805I	5.80.5I200	5.80.5I300	5.80.5I400
Prismatic Horizontal				
	ART.805K	5.80.5K200	5.80.5K300	5.80.5K400
Floating				
	ART.810W	5.81.0W200	5.81.0W300	5.81.0W400
Step (Small & Large)				
	ART.8100	5.81.00200	5.81.00300	5.81.00400
Double Step Fixed				
	ART.805Q	5.80.5Q200	5.80.5Q300	5.80.5Q400
Grip (3mm step with teeth)				
	ART.810T	5.81.0T200	5.81.0T300	5.81.0T400

Multiflex Vise with Fixed & Movable Step Jaws - Art. 606
 Multiflex Vise with Fixed & Movable Hard Jaws - Art. 600

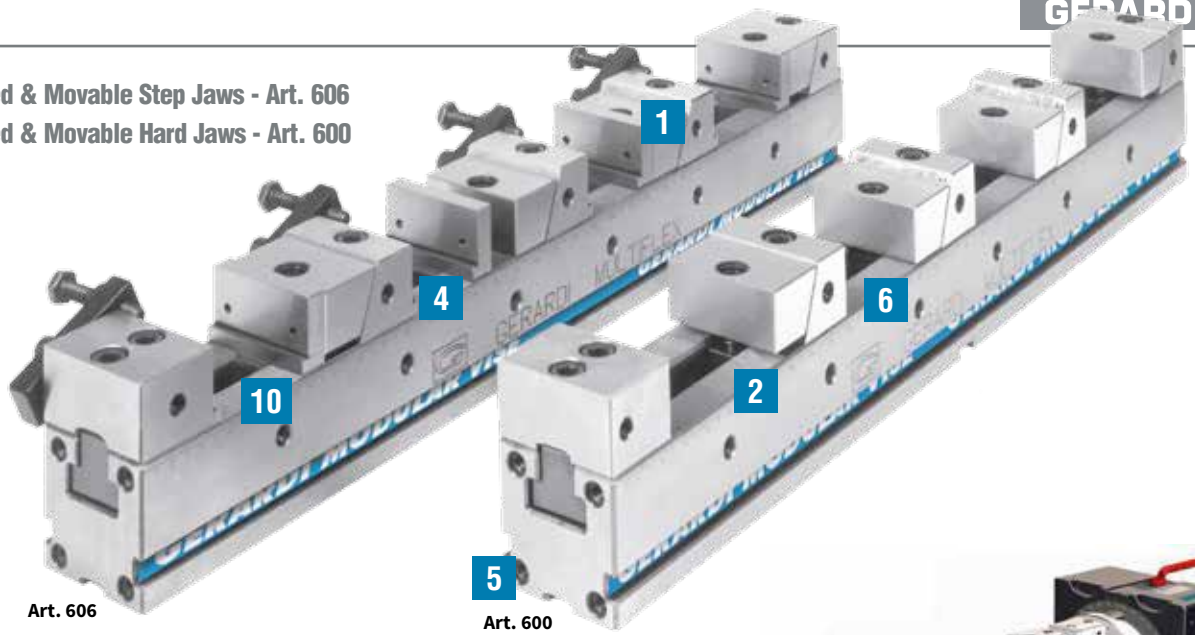

Art. 606

Art. 600

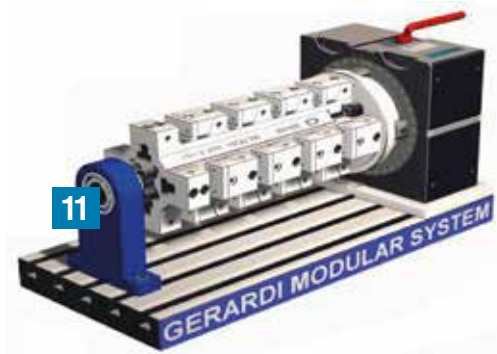
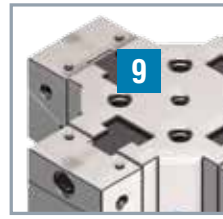
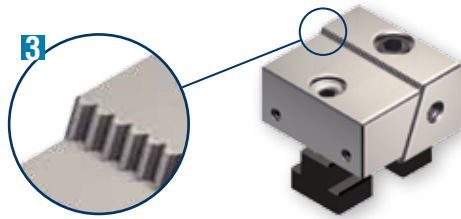

MADE IN ITALY

Multiflex Applications

IN LINE 7 workpieces clamped in line with 3 vises 	PARALLEL 28 workpieces clamped with 14 vises 	PLATES 4 plates clamped in line with 3 vises 	PARALLEL 14 workpieces clamped with 14 vises 	MIXED PLATES 3 plates clamped in line with 4 vises 	MULTIPLE 30 workpieces clamped with 5 vises
---	--	--	--	--	---

1	MODULAR	Wide range of spare jaws - use for clamping 1-12 workpieces ANYTHING is possible with Gerardi's standard jaws.
2	NO WEAR	Made 100% from high quality, case hardened HRC 60 alloyed resistance steel for maximum rigidity, high performance and no wear. 5 YEARS WARRANTY on vises and all components.
3	COMB CLAMP SYSTEM WITH PULL DOWN ACTION	High clamping accuracy, power and pull down action with Gerardi COMB CLAMPING action.
4	HIGHEST ACCURACY +/-0.02mm	Every sliding and working surface is ground. Centesimal tolerances are guaranteed by checking cycles with CNC measuring machine. The perfect alignment with the machine axis is given by keyways
5	VERTICAL OR HORIZONTAL SET UP	MULTIFLEX vises can be vertically assembled and linked to each other or clamped to specific workholding structures.
6	HIGH & CONSISTENT CLAMPING FORCES	20-30kN clamping forces achieved with simple T wrench.
7	IDEAL FOR 4 th AXIS COMPACT CORE	Ideal for turning a vertical machining centre into a full production machine. The small core size of the tower makes it ideal for even the smallest of rotary tables
8	TAILOR MADE BASE PLATES	ART.828A available made to order tailor made to suit your pallet (not included in price of tower)
9	H7 CENTRING HOLE	25mm diameter (Size 1) or 50mm diameter (Size 2&3)
10	ART.609 STEP MODULAR JAW	Can be used as a STEP JAW (supplied as standard) or SMOOTH JAW, SERRATED, PARALLEL or PRISMATIC JAW (see below)

Multiflex Vises

Multiflex Vise with Fixed & Movable Step Jaws - Art. 606

Multiflex Vise with Fixed & Movable Hard Jaws - Art. 600

Type	Jaw Height	Base Height	Length	Jaw Width	SPREAD mm	Art. 606 ORDER CODE	SPREAD mm	Art. 600 ORDER CODE
1 20kN	32/25	50	300	49	3 x 19	6.60.61300	4 x 8	6.60.01300
	32/25	50	400	49	4 x 23	6.60.61400	4 x 33	6.60.01400
	32/25	50	500	49	4 x 48	6.60.61500	4 x 58	6.60.01500
	32/25	50	600	49	4 x 73	6.60.61600	4 x 83	6.60.01600
	32/25	50	700	49	4 x 97	6.60.61700	4 x 108	6.60.01700
2 30kN	40	75	400	74	3 x 28	6.60.62400	4 x 12	6.60.02400
	40	75	500	74	4 x 24	6.60.62500	4 x 37	6.60.02500
	40	75	600	74	4 x 49	6.60.62600	4 x 62	6.60.02600
	40	75	700	74	4 x 74	6.60.62700	4 x 87	6.60.02700
	40	75	800	74	4 x 99	6.60.62800	4 x 112	6.60.02800
3 40kN	60	100	700	99	4 x 44	6.60.63700	4 x 59	6.60.03700
	60	100	800	99	4 x 69	6.60.63800	4 x 84	6.60.03800
	60	100	900	99	4 x 94	6.60.63900	4 x 109	6.60.03900
	60	100	1000	99	4 x 119	6.60.63100	4 x 134	6.60.03100

Supplied with Multiflex Vise:

4 x workstops - ART.370, 1 x T wrench - ART.376,
1 x pair of positioning keys (16mm),
6 x Table Clamps & T-Nuts

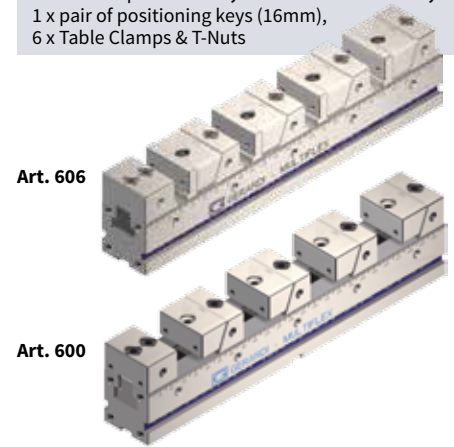

Multiflex Towers

Multiflex Tower With Fixed & Movable Step Jaws - Art. 607

Multiflex Tower With Fixed & Movable Hard Jaws - Art. 602





Type	Jaw Height	Tower Base Width	Length/Height	Jaw Width	Spread Mm	Art. 607 ORDER CODE	Spread mm	Art. 602 ORDER CODE
1 20kN	32/25	100	300	49	3 x 19	6.60.71300	16 x 8	6.60.21300
	32/25	100	400	49	4 x 23	6.60.71400	16 x 33	6.60.21400
	32/25	100	500	49	4 x 48	6.60.71500	16 x 58	6.60.21500
	32/25	100	600	49	4 x 73	6.60.71600	16 x 83	6.60.21600
	32/25	100	700	49	4 x 97	6.60.71700	16 x 108	6.60.21700
2 30kN	40	150	400	74	3 x 28	6.60.72400	16 x 12	6.60.22400
	40	150	500	74	4 x 24	6.60.72500	16 x 37	6.60.22500
	40	150	600	74	4 x 49	6.60.72600	16 x 62	6.60.22600
	40	150	700	74	4 x 74	6.60.72700	16 x 87	6.60.22700
	40	150	800	74	4 x 99	6.60.72800	16 x 112	6.60.22800
3 40kN	60	100	700	99	4 x 44	6.60.73700	16 x 59	6.60.23700
	60	100	800	99	4 x 69	6.60.73800	16 x 84	6.60.23800
	60	100	900	99	4 x 94	6.60.73900	16 x 109	6.60.23900
	60	100	1000	99	4 x 119	6.60.73100	16 x 134	6.60.23100

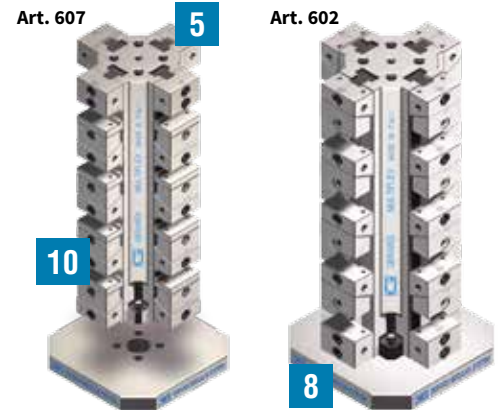



Supplied with Multiflex Tower:

16 x workstops - ART.370, 1 x T wrench - ART.376,
1 x pair of positioning keys (16mm)







Multiflex Jaws

	Vise SIZE (W)	Vise SIZE (W)		
		1 (49)	2 (74)	3 (99)
Fixed Serrated 	ART.604	6.60.41000	6.60.42000	6.60.43000
Fixed Smooth 	ART.604G	6.60.4G100	6.60.4G200	6.60.4G300
Fixed Grip 	ART.604T	6.60.4T100	6.60.4T200	6.60.4T300
Fixed Step 	ART.608	6.60.81000	6.60.82000	6.60.83000
Fixed Double Step 	ART.614T	6.61.4T100	6.61.4T200	6.61.4T300

	Vise SIZE (W)	Vise SIZE (W)		
		1 (49)	2 (74)	3 (99)
Movable Smooth 	ART.605	6.60.51000	6.60.52000	6.60.53000
Movable Serrated 	ART.605S	6.60.5S100	6.60.5S200	6.60.5S300
Movable Step 	ART.609	6.60.91000	6.60.92000	6.60.93000
Movable Grip 	ART.609T	6.60.9T100	6.60.9T200	6.60.9T300

Optional Jaw Plates for Modular Step Jaw
- Art.609

	Vise SIZE (W)	Vise SIZE (W)		
		1 (49)	2 (74)	3 (99)
Soft 	ART.610B	6.61.0B100	6.61.0B200	6.61.0B300
Smooth 	ART.610C	6.61.0C100	6.61.0C200	6.61.0C300
Serrated 	ART.610D	6.61.0D100	6.61.0D200	6.61.0D300
Parallel 	ART.610E	6.61.0E100	6.61.0E200	6.61.0E300
Prismatic 	ART.610F	6.61.0F100	6.61.0F200	6.61.0F300

Clamp on Just 3mm for Full 5 Sided Machining

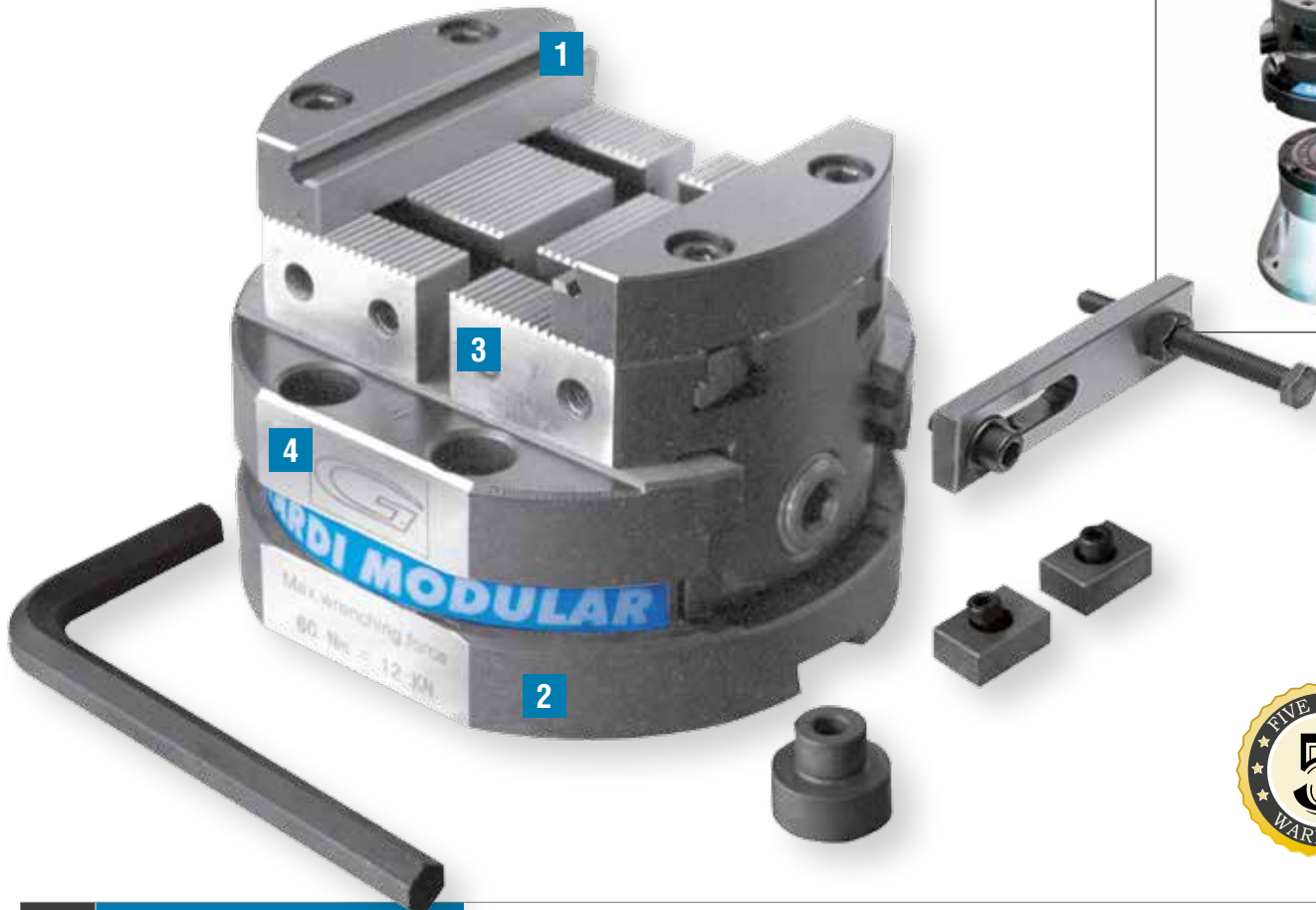

1	3-5mm STEP JAW	Supplied with 5mm step jaw as standard for full 5 sided machining. 3mm GRIP jaw also available.
2	NO WEAR	Made 100% from high quality, case hardened HRC 60 alloyed resistance steel in order to give maximum rigidity, high performance and no wear. 5 YEARS WARRANTY on all the vises and components.
3	SELF CENTRING OR ECCENTRIC ADJUSTMENT	Self centering with possibility of clamping inside to outside and vice versa. Eccentric jaw adjustments of 2mm.
4	GROUND SURFACES HIGHEST ACCURACY +/-0,02mm	Every sliding and working surface is ground. Centesimal tolerances are guaranteed by checking cycles with CNC measuring machine. The perfect alignment with the machine axis is given by keyways
5	DIRECT VISE SET-UP	Supplied with ground positioning keys for clamping through keyways and positioning pin for 5th axis.
6	MONO-BLOCK SPACER	Spacers machined from 1 solid piece of heat treated alloy steel
7	TAPPED & REAMED HOLES	Upto 26 (depending on size of space) reamed and tapped holes for positioning vise/spacer to table or 5th axis.
8	REVERSIBLE DOUBLE STEP JAW	Size 3 Multitasking vise supplied with reversible step jaw. 5mm step on both sides, large step on inside.
9	ZERO POINT	Reduce set-up times by 95%. Immediate positioning within 5 microns, pneumatic clamping of the vise to the Zero Point via pull calibrated stud.

Supplied with Every Multitasking Vise:

- 1 x workstop **ART.370**,
- 1 x pair of positioning keys (16mm),
- 1 x positioning pin,
- 1 x hex wrench **ART.376**

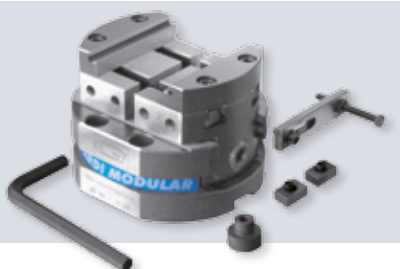

Multitasking Vises

Art. 640 Size 1&2

Art. 640 Size 3-166

Art. 640 Size 3-266



8

Multitasking Spacers

Art. 641H

Art. 641H

Art. 641H

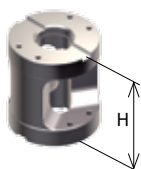

Supplied with 1 straight pin **Art. 79** & 1 positioning pin **Art. 640P**

Multitasking Jaws

Art. 645B
Soft

Art. 645F
Prismatic

Art. 645T
Grip (3mm step)

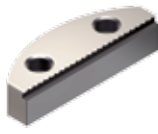

Art. 645D
Serrated

Art. 645B
Hard Smooth

Art. 655J
Prismatic Large

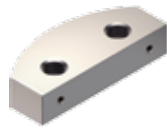
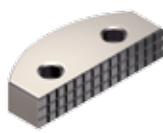

3

Pneumatic Zero Point Module

- Quickest set up, practically immediate
- Pre-set workpieces offline
- Greatest reduction in scrap (if re-work is needed you can put back on the machine in same place within 5 microns)
- Typically Zero Point used in 3 machining centres creates as much capacity as 1 new VMC (for about 15% of the cost)

**QUICKEST
RETURN ON
INVESTMENT!**
Payback 1 Month

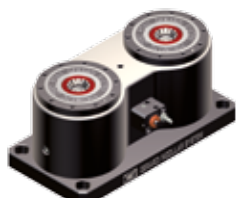

Multitasking Vises & Accessories

Vise Size	1	2	3	
Jaw Width	74	99	138	138
Max Opening	74	104	108	288
Jaw Height	15	20	30	30
Total Height	85	115	113	113
Base Size	ø120	ø160	145 x 166	145 x 266

Multitasking Vises

ORDER CODE	6.64.01000	6.64.02000	7.64.03166	7.64.03266
------------	------------	------------	------------	------------

Multitasking Spacers

H= 130mm - ORDER CODES	7.64.1H100/130	7.64.1H200/130	7.64.1H3166/145*	7.64.1H3266/145*
H= 100mm - ORDER CODES	7.64.1H100/100	7.64.1H200/100	7.64.1H3166/100	7.64.1H3266/100
H= 75mm - ORDER CODES	7.64.1H100/75	7.64.1H200/75	7.64.1H3166/75	7.64.1H3266/75
H= 50mm - ORDER CODES	7.64.1H100/50	7.64.1H200/50	7.64.1H3166/50	7.64.1H3266/50

*H = 145mm

Multitasking Jaws

ART645B SOFT JAW	6.64.5B100	6.64.5B200	7.64.5B300
ART645C HARD JAW	6.64.5C100	6.64.5C200	7.64.5C300
ART645D SERRATED JAW	6.64.5D100	6.64.5D200	7.64.5D300
ART645F PRISMATIC JAW	6.64.5F100	6.64.5F200	7.64.5F300
ART645T GRIP JAW	6.64.5T100	6.64.5T200	7.64.5T300

Zero Point Module (Spacer, Zero Point, Pull Stud, Pin, Screw)

ORDER CODE	9.63.20000	9.64.20000
------------	------------	------------

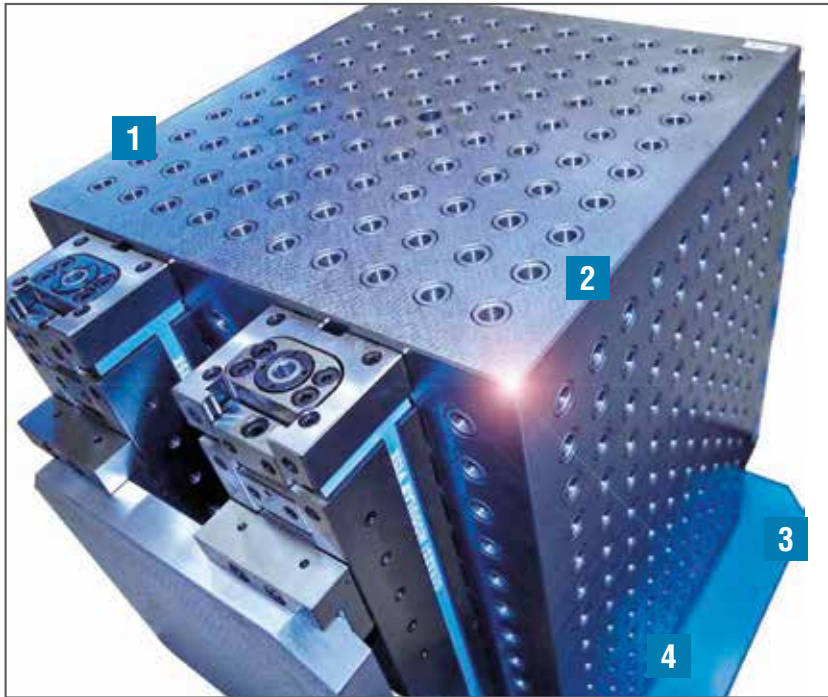

1	Cast Iron G30 CASTING - no fabrication! MORE RIGID - HIGHER PRECISION
2	Double stress relieving heat treatment
3	Hand scraping of bottom of base for perfect planarity
4	Base face tailor made ready to fit onto the specific machine tool pallet

Available in 4 Finishes

A	TYPE A - rough milled with 43-45mm wall thickness.
B	TYPE B - rough milled with 43-45mm wall thickness. Base with 4x Ø20mmF7 holes & M16 bottom threads
C	TYPE C - Completely machined all over +0.02mm. Base with 4x Ø20mmF7 holes & M16 bottom threads
D	TYPE E - As per type C but with calibrated M16threads. Base with 4x Ø20mmF7 holes & M16 bottom threads

A Rough Milled

General tolerance ± 2 mm

Cube, Art.53A

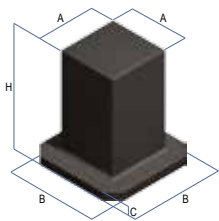

A	B	C	H	kg	ORDER CODE
260	410	50	670	239	8.53.A00081
260	410	50	560	207	8.53.A00080
280	410	50	520	210	8.53.A00110
260	510	50	760	280	8.53.A00105
360	510	50	710	372	8.53.A00171
460	640	50	560	431	8.53.A00190
460	640	50	660	486	8.53.A00200
510	640	50	870	655	8.53.A00211

B Rough Milled, Base Prepared

General tolerance ± 2 mm

Cube, Art. 53B

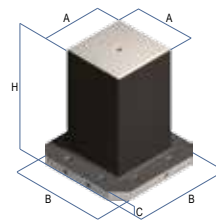

A	B	C	H	kg	ORDER CODE
260	400	45	660	228	8.53.B00081
260	400	45	550	197	8.53.B00080
280	400	45	510	198	8.53.B00110
260	500	45	750	283	8.53.B00105
360	500	45	700	356	8.53.B00171
460	630	45	550	409	8.53.B00190
460	630	45	650	463	8.53.B00200
510	630	45	860	631	8.53.B00211

2 Sided Tombstone, Art.55A

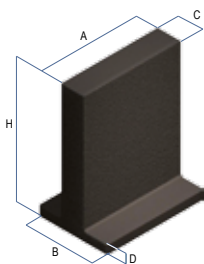

A	B	C	D	H	kg	ORDER CODE
410	410	160	60	510	215	8.55.A00051
410	410	160	55	670	262	8.55.A00052
510	510	160	55	710	350	8.55.A00053
510	510	210	60	610	340	8.55.A00054
560	460	160	60	830	430	8.55.A00160
640	460	160	60	830	486	8.55.A00170
640	460	260	70	910	630	8.55.A00171
640	640	210	60	870	579	8.55.A00172
640	640	260	60	710	521	8.55.A00173
360	460	160	70	660	250	8.55.A00180
810	460	160	70	860	649	8.55.A00190

2 Sided Tombstone, Art.55B

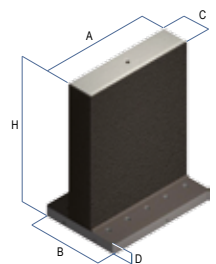

A	B	C	D	H	kg	ORDER CODE
400	400	160	55	500	199	8.55.B00051
400	400	160	50	660	244	8.55.B00052
500	500	160	50	700	331	8.55.B00053
500	500	210	55	600	316	8.55.B00054
550	450	160	55	820	406	8.55.B00160
630	450	160	55	820	460	8.55.B00170
630	450	260	65	900	600	8.55.B00171
630	630	210	55	850	545	8.55.B00172
630	630	260	55	700	485	8.55.B00173
350	450	160	65	650	232	8.55.B00180
800	450	160	65	850	610	8.55.B00190

Cross Cube, Art.57A

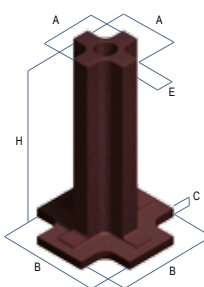

A	B	C	E	H	kg	ORDER CODE
210	510	45	80	760	172	8.57.A0100
210	510	45	80	660	156	8.57.A0105
260	510	45	80	760	212	8.57.A0106
280	510	45	80	860	251	8.57.A0110
240	510	45	110	860	237	8.57.A0120
310	510	45	150	860	291	8.57.A0130
310	640	45	150	960	357	8.57.A0140
380	510	45	200	960	500	8.57.A0145

More sizes and bespoke designs on request.

Cross Cube, Art.57B

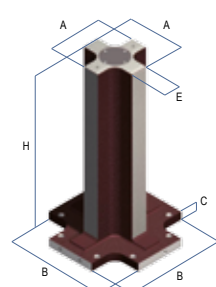

A	B	C	E	H	kg	ORDER CODE
203	500	40	80	750	157	8.57.B0100
203	500	40	80	650	142	8.57.B0105
253	500	40	80	750	197	8.57.B0106
273	500	40	80	850	235	8.57.B0110
233	500	40	110	850	218	8.57.B0120
303	500	40	150	850	269	8.57.B0130
303	630	40	150	950	327	8.57.B0140
373	500	40	200	950	387	8.57.B0145

More sizes and bespoke designs on request.

Complete Pallets for Your Machining Centre

Grid Pallet Art. 85

Pallet with H7 T-Slot Art. 86



Please state machine and model number when ordering.

	MACHINE PALLET SIZE			
	400mm	500mm	630mm	800mm
GRID PALLET - ART. 85				
ORDER CODE	8.85.404000	8.85.505000	8.85.636300	8.85.808000
PALLET WITH H7 T-SLOT - ART. 86				
ORDER CODE	8.86.404000	8.86.505000	8.86.636300	8.86.808000

Steel Pallet Base Plates

Grid Pallet Base Plate Art. 60E

Pallet Base Plate With H7 T-Slot Art. 60G

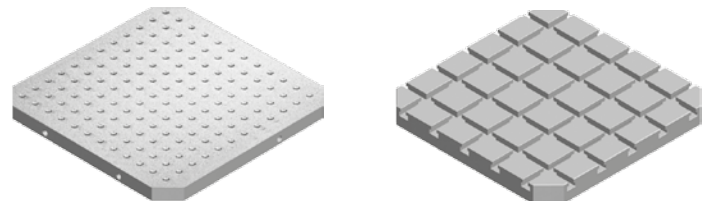

ART.60E Please specify grid pitch. **ART.60G** Please specify T-Slot size

	MACHINE PALLET SIZE			
	400mm	500mm	630mm	800mm
GRID PALLET BASE PLATE - ART. 60E				
ORDER CODE	8.60.E400400A	8.60.E500500A	8.60.E630630A	8.60.E800800A
PALLET BASE PLATE WITH H7 T-SLOT - ART. 60G				
ORDER CODE	8.60.G400400A	8.60.G500500A	8.60.G630630A	8.60.G800800A

C Completely Machined

General tolerance ± 0.02 mm

Cube, Art. 53C

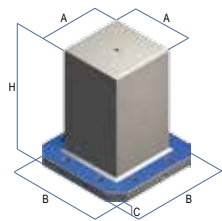

A	B	C	H	kg	ORDER CODE
250	400	40	660	201	8.53.C00081
250	400	40	550	174	8.53.C00080
270	400	40	510	176	8.53.C00110
250	500	40	750	250	8.53.C00105
350	500	40	700	317	8.53.C00171
450	630	40	550	367	8.53.C00190
450	630	40	650	415	8.53.C00200
500	630	40	860	565	8.53.C00211

2 Sided Tombstone, Art.55C

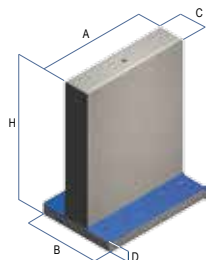

A	B	C	D	H	kg	ORDER CODE
400	400	150	50	500	193	8.55.C00051
400	400	150	45	660	222	8.55.C00052
500	500	150	45	700	290	8.55.C00053
500	500	200	50	600	287	8.55.C00054
550	450	150	50	820	369	8.55.C00160
630	450	150	50	820	418	8.55.C00170
630	450	250	60	900	508	8.55.C00171
630	630	200	50	850	504	8.55.C00172
630	630	250	50	700	447	8.55.C00173
350	450	150	60	650	213	8.55.C00180
800	450	150	60	850	555	8.55.C00190

Cross Cube, Art.57C

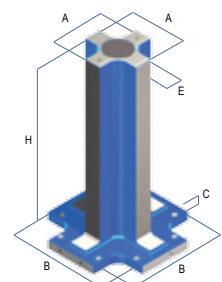

A	B	C	E	H	kg	ORDER CODE
200	500	40	80	750	154	8.57.C0100
200	500	40	80	650	140	8.57.C0105
250	500	40	80	750	194	8.57.C0106
270	500	40	80	850	232	8.57.C0110
230	500	40	110	850	214	8.57.C0120
300	500	40	150	850	264	8.57.C0130
300	630	40	150	950	322	8.57.C0140
370	500	40	200	950	379	8.57.C0145

More sizes and bespoke designs on request.

D Grid

General tolerance ± 0.02 mm

Cube, Art. 53E

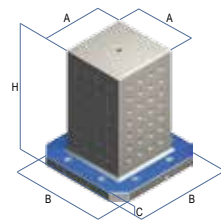

A	B	C	H	kg	ORDER CODE
250	400	40	660	201	8.53.E00081
250	400	40	550	174	8.53.E00080
270	400	40	510	176	8.53.E00110
250	500	40	750	250	8.53.E00105
350	500	40	700	317	8.53.E00171
450	630	40	550	367	8.53.E00190
450	630	40	650	415	8.53.E00200
500	630	40	860	565	8.53.E00211

2 Sided Tombstone, Art.55E

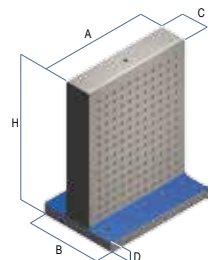

A	B	C	D	H	kg	ORDER CODE
400	400	150	50	500	193	8.55.E00051
400	400	150	45	660	222	8.55.E00052
500	500	150	45	700	290	8.55.E00053
500	500	200	50	600	287	8.55.E00054
550	450	150	50	820	369	8.55.E00160
630	450	150	50	820	418	8.55.E00170
630	450	250	60	900	508	8.55.E00171
630	630	200	50	850	504	8.55.E00172
630	630	250	50	700	447	8.55.E00173
350	450	150	60	650	213	8.55.E00180
800	450	150	60	850	555	8.55.E00190

Cross Cube, Art.57E

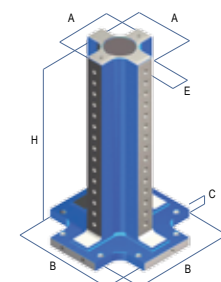

A	B	C	E	H	kg	ORDER CODE
200	500	40	80	750	154	8.57.E40100
200	500	40	80	650	140	8.57.E40105
250	500	40	80	750	194	8.57.E40106
270	500	40	80	850	232	8.57.E40110
230	500	40	110	850	214	8.57.E40120
300	500	40	150	850	264	8.57.E40130
300	630	40	150	950	322	8.57.E40140
370	500	40	200	950	379	8.57.E40145

More sizes and bespoke designs on request.

Zero Point Modules

Built-in Mounting
Pneumatic
Art. 665 Type 2

Standard 9kN
UP TO 18kN*

* With booster



ORDER CODE

8.66.52000

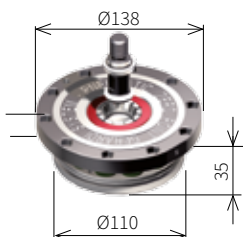

Built-in Mounting
Single Pneumatic (with Keyway)
Art. 665S Type 1

Standard 4.7kN
UP TO 11kN*

* With booster



ORDER CODE

9.66.51000

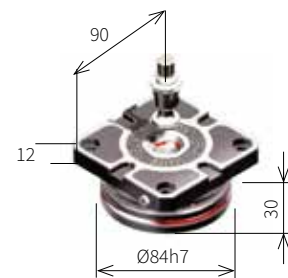

Mounting with Flange
Pneumatic
Art. 664 Type 2

Standard 9kN
UP TO 18kN*

* With booster



ORDER CODE

8.66.42000

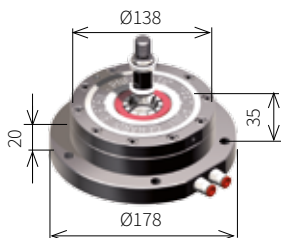

Mounting with Flange
Single Pneumatic (with Keyway)
Art. 664S Type 2

Standard 4.7kN
UP TO 11kN*

* With booster



ORDER CODE

9.66.41000

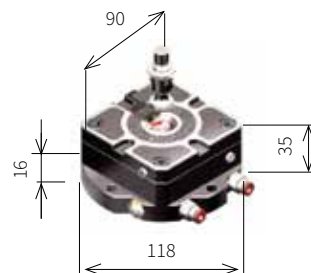

Zero Point Interface Plates with Built In Mounted Zero Point Modules Art. 665

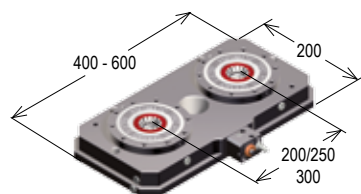

Art. 81P with Art. 665 x 2	BASE PLATE		
	200 x 400	200 x 500	200 x 600
ORDER CODE	9.81.P2040S2	9.81.P2050S2	9.81.P2060S2

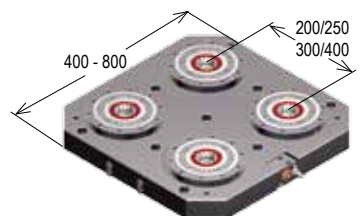

Art. 80P with Art. 665 x 4	BASE PLATE			
	400 x 400	500 x 500	630 x 630	800 x 800
ORDER CODE	9.80.P4040S4	9.80.P5050S4	9.80.P6363S4	9.80.P8080S4

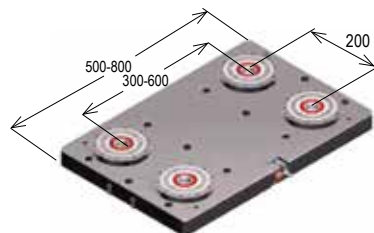

Art. 81P with Art. 665 x 4	BASE PLATE			
	400 x 500	400 x 600	400 x 700	400 x 800
ORDER CODE	9.81.P4050S4	9.81.P4060S4	9.81.P4070S4	9.81.P4080S4

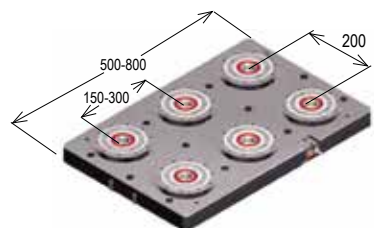

Art. 81P with Art. 665 x 6	BASE PLATE			
	400 x 500	400 x 600	400 x 700	400 x 800
ORDER CODE	9.81.P4050S6	9.81.P4060S6	9.81.P4070S6	9.81.P4080S6

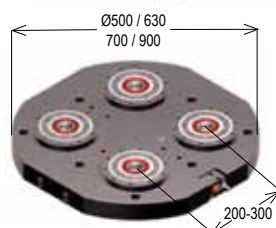

Art. 82P with Art. 665 x 4*	BASE PLATE			
	Ø 500	Ø 630	Ø 700	Ø 900*
ORDER CODE	9.82.P5040S4	9.82.P6350S4	9.82.P7050S4	9.82.P9063S6

*9.82P9063S6 has 6 Zero Point Modules Art. 665

Zero Point Interface Plate & Vise Kits

- Vise positioning and clamping through 2 Zero Points instead of 4 clamps and 2 tenons
- 5µm Repeatability

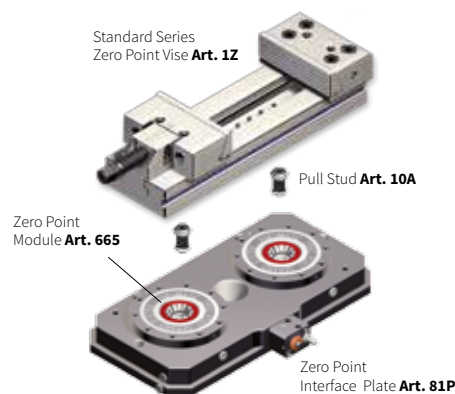

Kit A

Standard Series 150 x 200mm Zero Point Vise **Art. 1Z**
with Zero Point Interface Plate 200 x 400 **Art. 81.P**



ORDER CODE

ART1ZKIT-A

Kit B

Standard Series 150 x 300mm Zero Point Vise **Art. 1Z**
with Zero Point Interface Plate 200 x 400 **Art. 81.P**



ORDER CODE

ART1ZKIT-B

Built-in Mounting
Single Pneumatic (with Keyway)
Art. 665S Type 2

Standard 9kN
UP TO 18kN*



* With booster

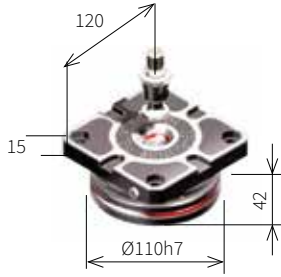

ORDER CODE
9.66.55200

Mounting with Flange
Single Pneumatic (with Keyway)
Art. 664S Type 2

Standard 9kN
UP TO 18kN*



* With booster

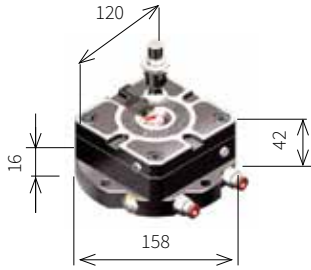

ORDER CODE
9.66.45200

FREE!

1 Pull-stud &
1 teflon cup with
O-Ring **Art. 9**

**WITH EVERY
ZERO POINT
MODULE**



Quickest Return On Your Investment

- Quickest set up, practically immediate
- Pre-set workpieces offline
- Greatest reduction in scraps (if re-work is need you can put back on the machine in same place)
- Typically Zero Point used in 3 machining centres creates as much capacity as 1 new VMC (for about 15% of the cost)

Zero Point
Interface Plate
200 x 400 **Art. 81P**

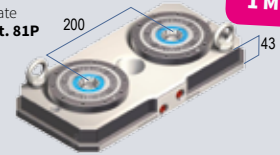

**PAYBACK IN
1 MONTH***

ORDER CODE
9.81.P204052

*Calculation based on 2 hours daily set up time saving at £35 per hour for 50 working weeks.

This also gives a potential extra profit of £15,400 per annum

Zero Point Accessories

Kit for Single Operation
Excludes Zero Point Module
Art. 407C

ORDER CODE 9.40.7C000

Kit for Double Operation
Excludes Zero Point Module
Art. 407C2

ORDER CODE 9.40.7C200

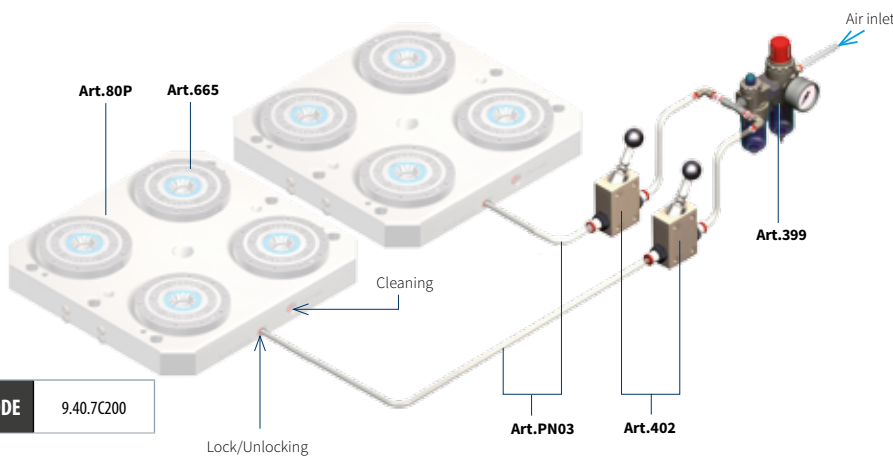
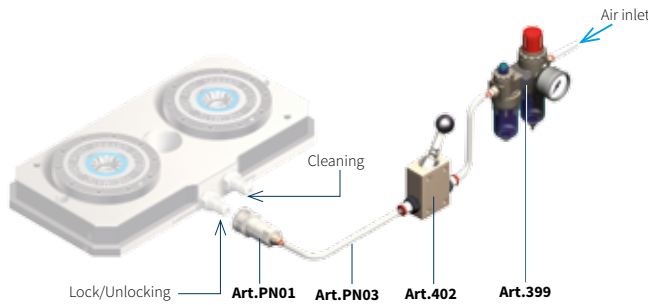

Zero Point Applications

Plate interfaced with vises assembled

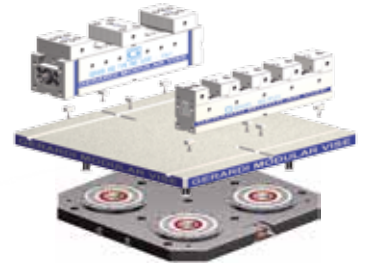

Plate interfaced with special fixtures assembled

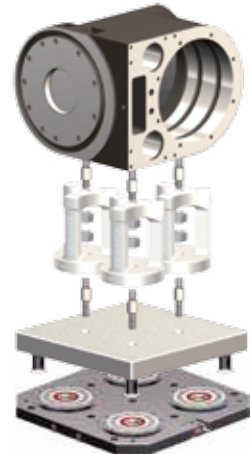

Plate interfaced with workpiece assembled ready to be machined



Pull Studs

Centring Pull Stud
Female thread
Art. 10A



ORDER CODE 9.10.A2000

Clamping Pull Stud
Female thread
Art. 10B



ORDER CODE 9.10.B2000

Centring Pull Stud
Male thread
Art. 11A



ORDER CODE 9.11.A2000

Clamping Pull Stud
Male thread
Art. 11B



ORDER CODE 9.11.B2000

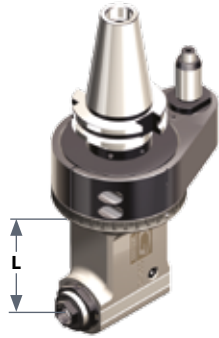

THE WORLD'S MOST POPULAR ANGLE HEADS

► Case hardened and ground shank and shaft

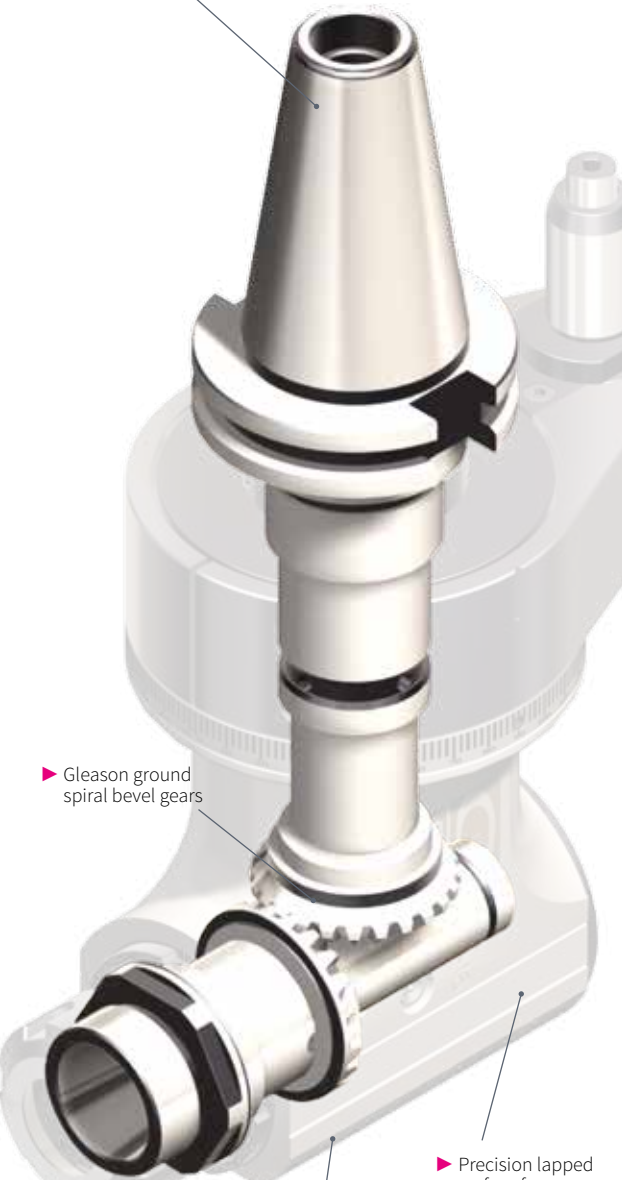

► Gleason ground spiral bevel gears

► Precision lapped surface for accurate alignment

► **OUTPUT:**
- ER Collet (std)
- Weldon
- Shell mill holder
- Special

► Treated steel head body with 360° position and internal air pressure, maximum rigidity and corrosion resistant. Minimum thermal expansion

ATC Series Angle Heads (Automatic Tool Change)



*Min bore for internal machining. Excludes cutting tool

Type 1 (Ø90)



Model	Output	L	Ø _{min} *	Rpm	Nm	ORDER CODE
G90-7	ER-11-Ø1/7	102	68	6000	5	9.G90.07000
G90-7L	ER-11-Ø1/7	147	68	6000	5	9.G90.07L00
G90-10	ER-16-Ø1/10	82	87	6000	10	9.G90.10000
G90-10L	ER-16-Ø1/10	157	87	6000	10	9.G90.10L00
G90-16	ER-25-Ø1/16	82	130	4000	24	9.G90.16000
G90-16L	ER-25-Ø1/16	152	130	4000	24	9.G90.16L00
GMU-13	ER-20-Ø1/13	67	120	4000	6	9.GMU.13000
GMU-16	ER-25-Ø1/16	82	142	4000	18	9.GMU.16000

Type 2 (Ø110)

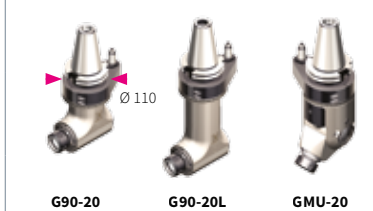

G90-20	ER-32-Ø2/20	92	164	4000	40	9.G90.20000
G90-20L	ER-32-Ø2/20	172	164	4000	40	9.G90.20L00
GMU-20	ER-32-Ø2/20	92	165	4000	32	9.GMU.20000

Type 3 (Ø170)



G90-S40	ISO40/CAT/BT40	110	192	4000	140	9.G90.S4000
G90-S40L	ISO 40/CAT/BT40	170	192	4000	140	9.G90.S40L00

MTC Series Angle Heads (Manual Tool Change)

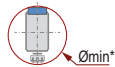

*Min bore for internal machining. Excludes cutting tool



Model	Output	L	Ø _{min} *	Rpm	ORDER CODE
G90-S40XL	ISO/CAT/BT40	250	205	4000	9.G90.S40XL1
G90-S40XL.400	ISO/CAT/BT40	400	202	4000	9.G90.S40.XL.400
G90-S40XL.500	ISO/CAT/BT40	500	202	4000	9.G90.S40.XL.500
G90-S40XL.600	ISO/CAT/BT40	600	202	4000	9.G90.S40.XL.600
G90-S40XL.700	ISO/CAT/BT40	700	202	4000	9.G90.S40.XL.700
G90-S50	ISO/CAT/BT50	300	305	3000	9.G90.S5001
G90-S50XL.400	ISO/CAT/BT50	400	297	3000	9.G90.S50XL.400
G90-S50XL.500	ISO/CAT/BT50	500	297	3000	9.G90.S50XL.500
G90-S50XL.600	ISO/CAT/BT50	600	297	3000	9.G90.S50XL.600
G90-S50XL.700	ISO/CAT/BT50	700	297	3000	9.G90.S50XL.700
GMU-16	ER-25 Ø1-16	82	142	4000	9.GMU.16001
GMU-20	ER-32 Ø2-20	92	165	4000	9.GMU.20001
GMU-S40	ISO40/CAT/BT40	250	300	3000	9.GMU.S4001
GMU-S50	ISO 40/CAT/BT40	300	420	3000	9.GMU.S5001

ATC Series Angle Heads (Automatic Tool Change)

One Head for Many Machines

INTERCHANGEABLE DRIVE TAPERS TO FIT ANY MACHINE SPINDLE!

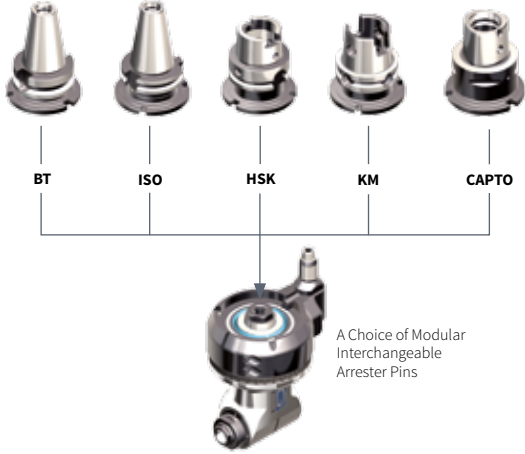

*Min bore for internal machining. Excludes cutting tool

Type 1 (Ø 102)



Model	Output	L	Ø min*	Rpm	Nm	ORDER CODE
FS90-3	6023E - Ø1/3	142,5	35	8000	2	9.FS9.03000
FS90-3L	6023E - Ø1/3	170,5	35	8000	2	9.FS9.03L00
FS90-4	600E - Ø1/4	144,5	39	8000	3,5	9.FS9.04000
FS90-4L	600E - Ø1/4	183	39	8000	3,5	9.FS9.04L00
F90-7	ER11 - Ø1/7	116	68	10000	6	9.F90.07000
F90-7L	ER11 - Ø1/7	176	75	10000	6	9.F90.07L00
F90-10	ER16 - Ø1/10	106	94	10000	11	9.F90.10000
F90-10L	ER16 - Ø1/10	176	94	10000	11	9.F90.10L00
F90-16S	ER25 - Ø1/16	86	132	8000	27	9.FMU.16000
FMU-10	ER16 - Ø1/10	66	118	4000	9	9.FMU.10000
FMU-16	ER25 - Ø1/16	76	152	3000	15	9.FMU.16000

The Same Machine with Many Heads

A SYSTEM TO SAVE COSTS !

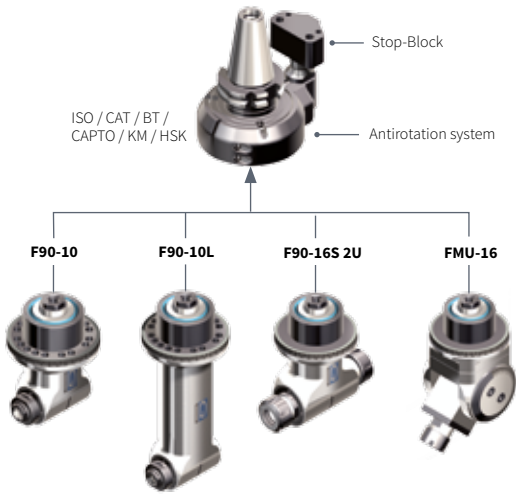

Type 2 (Ø 128)



F90-16	ER25 - Ø1/16	100	126	5000	46	9.F90.16000
F90-16L	ER25 - Ø1/16	200	126	5000	46	9.F90.16L00
F90-20	ER32 - Ø2/20	108	168	3500	85	9.F90.20000

Type 3 (Ø 157)

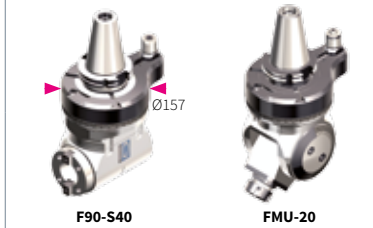

F90-S40	ISO-CAT BT40	115	204	2500	135	9.F90.S4000
FMU-20	ER32 - Ø2/20	96	203	2500	48	9.FMU.20000

Spindle Speeders (Automatic Tool Change)



Model	Output	i	Rpm Max	ORDER CODE
GSS-10HS	ER16 - Ø1/10	1:8	35000	9.GS.S10HS
GSS-10	ER16 - Ø1/10	1:6	22000	9.GS.S1000
GSS-13	ER20 - Ø1/13	1:6	22000	9.GS.S1300
GSS-16	ER25 - Ø1/16	1:6	15000	9.GS.S1600
GSS-20	ER32 - Ø2/20	1:6	12000	9.GS.S2000
GSS-26	ER40 - Ø3/26	1:4.2	10000	9.GS.S2600
GSS-34	ER50 - Ø3/34	1:4	8000	9.GS.S3400

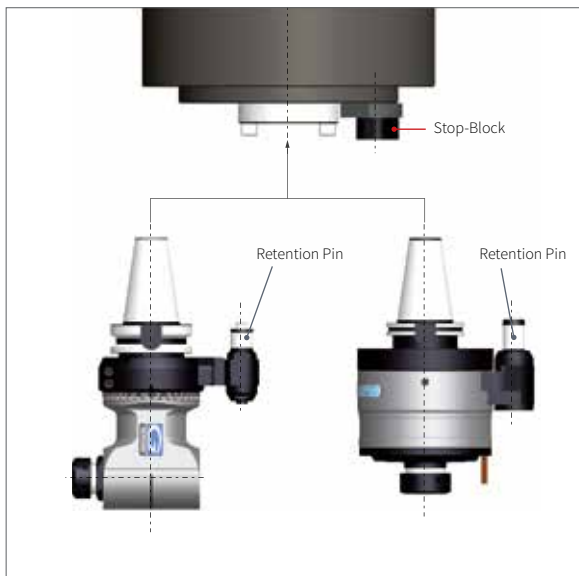

VDI DIN 69880 (DIN5480)

Axial

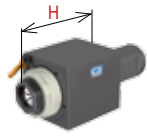

d1	Coolant	ER	H	Nm	Rpm	ORDER CODE
30	Ext.	25	66	32	5000	99.ST.8003
	Int/Ext	25	66	32	5000	99.ST.8011
40	Ext.	32	95	63	4000	99.ST.8005
	Int/Ext	32	95	63	4000	99.ST.8013

Radial*

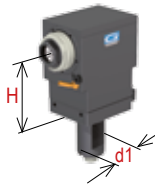

d1	Coolant	ER	H	Nm	Rpm	ORDER CODE
30	Ext.	25	55	32	5000	99.ST.8030
	Int/Ext	25	55	32	5000	99.ST.8038
40	Ext.	32	100	63	4000	99.ST.8033
	Int/Ext	32	100	63	4000	99.ST.8041

*Direction of rotation opposite to machine spindle

VDI DIN 69880 (DIN5482)

Axial

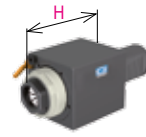

d1	Coolant	ER	H	Nm	Rpm	ORDER CODE
30	Ext.	25	94	32	5000	99.ST.8201
	Int/Ext	25	94	32	5000	99.ST.8207
40	Ext.	32	115	63	4000	99.ST.8203
	Int/Ext	32	115	63	4000	99.ST.8209

Radial*

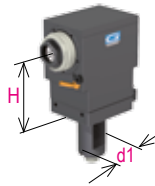

d1	Coolant	ER	H	Nm	Rpm	ORDER CODE
30	Ext.	25	55	32	5000	99.ST.8217
	Int/Ext	25	55	32	5000	99.ST.8223
40	Ext.	32	100	63	4000	99.ST.8220
	Int/Ext	32	100	63	4000	99.ST.8226

*Direction of rotation opposite to machine spindle

Mori Seiki

NL 1500 - 2000 - 2500 - 3000

Axial

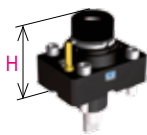

ER	Coolant	H	Nm	Rpm	ORDER CODE
32	Ext.	86÷89.8	60	6000	99.MS.A59
32	Int/Ext	86÷89.8	60	6000	99.MS.A60

Radial*

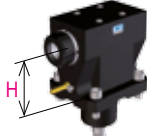

ER	Coolant	H	Nm	Rpm	ORDER CODE
32	Ext.	99.5÷103.5	60	6000	99.MS.A72
32	Int/Ext	99.5÷103.5	60	6000	99.MS.A73

*Direction of rotation opposite to machine spindle

NZ 1500 - 2000 - 3100 - 3150 - 3200

Axial

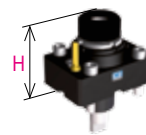

ER	Coolant	H	Nm	Rpm	ORDER CODE
25	Ext.	84.3	50	12000	99.MS.A101
25	Int/Ext	84.3	50	12000	99.MS.A102

Radial*

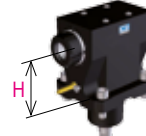

ER	Coolant	H	Nm	Rpm	ORDER CODE
32	Ext.	85	50	12000	99.MS.A108
32	Int/Ext	85	50	12000	99.MS.A109

*Direction of rotation opposite to machine spindle

Haas

h1: 117.5 VDI 40 TURRET SL40-ST20/30, HYBRID TURRET SL20/30 - TL15/25, HAAS TURRET SL20/30

h1: 104.8 VDI 40 TURRET SL20/30

Axial

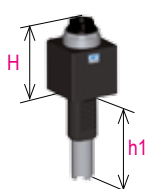

ER	Coolant	H	h1	Nm	Rpm	ORDER CODE
32	Ext.	75	117.5	63	6000	99.HA.590082
32	Int/Ext	75	117.5	63	6000	99.HA.590082B
32	Ext.	75	104.8	63	6000	99.HA.590083
32	Int/Ext	75	104.8	63	6000	99.HA.590083B

Radial

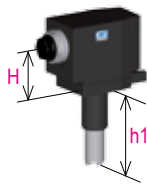

ER	Coolant	H	h1	Nm	Rpm	ORDER CODE
32	Ext.	75	117.5	63	6000	99.HA.590084
32	Int/Ext	75	117.5	63	6000	99.HA.590084B
32	Ext.	75	104.8	63	6000	99.HA.590085
32	Int/Ext	75	104.8	63	6000	99.HA.590085B

Nakamura

BMT 44 - WT100 - TW10

BMT 55 - SUPER NTJ-NTJX / NTM 3 / TMC 18 / TW10 / SC150-250 / WT150-250 / WTW 150 / WTS 150 / WT100

Axial

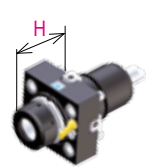

BMT	Coolant	ER	H	Nm	Rpm	ORDER CODE
44	Ext.	25	53.2÷57.6	40	6000	99.NK.A40
	Int/Ext	25	53.2÷57.6	40	6000	99.NK.A43
55	Ext.	32	67.5÷72	63	6000	99.NK.A03
	Int/Ext	32	67.5÷72	63	6000	99.NK.A04

Radial*



BMT	Coolant	ER	H	Nm	Rpm	ORDER CODE
44	Ext.	25	60	40	6000	99.NK.A50
	Int/Ext	25	60	40	6000	99.NK.A53
55	Ext.	32	55	63	6000	99.NK.A13
	Int/Ext	32	55	63	6000	99.NK.A14

*Direction of rotation opposite to machine spindle



VDI DIN 69880 (DIN1809)



Axial

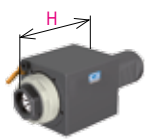

d1	Coolant	ER	H	Nm	Rpm	ORDER CODE
30	Ext.	25	94	32	5000	99.DP.0903
	Int/Ext	25	94	32	5000	99.DP.0910
40	Ext.	32	115	63	4000	99.DP.0905
	Int/Ext	32	115	63	4000	99.DP.0912

Radial*

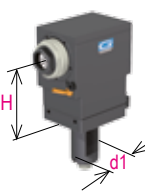

d1	Coolant	ER	H	Nm	Rpm	ORDER CODE
30	Ext.	25	55	32	5000	99.DP.0919
	Int/Ext	25	55	32	5000	99.DP.0922
40	Ext.	32	100	63	4000	99.DP.0926
	Int/Ext	32	100	63	4000	99.DP.0928

*Direction of rotation opposite to machine spindle

Mazak

Quick Turn Nexus QTN 100/150 & SQT 10 (12 station turret)
QTN 200/250 - SQT 15/18 - 200/250 (16 station turret)

Axial*

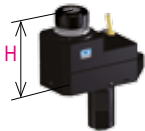

ER	Coolant	H	Nm	Rpm	ORDER CODE
25	Ext.	120	63	6000	99.MZ.A40
25	Int/Ext	120	63	6000	99.MZ.A41

*Direction of rotation opposite to machine spindle

Radial*

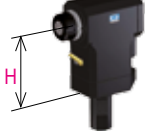

ER	Coolant	H	Nm	Rpm	ORDER CODE
32	Ext.	100	80	6000	99.MZ.A46
32	Int/Ext	100	80	6000	99.MZ.A47

*Direction of rotation opposite to machine spindle

Quick Turn Nexus QTN 200/250 (12 station turret)
Super Quadrex Turn SQT 15/18 - 200/250 (12 station turret)

Axial*

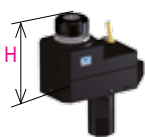

ER	Coolant	H	Nm	Rpm	ORDER CODE
32	Ext.	116	80	6000	99.MZ.A58
32	Int/Ext	116	80	6000	99.MZ.A59

*Direction of rotation opposite to machine spindle

Radial*

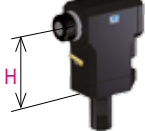

ER	Coolant	H	Nm	Rpm	ORDER CODE
32	Ext.	130	80	6000	99.MZ.A65
32	Int/Ext	130	80	6000	99.MZ.A66

*Direction of rotation opposite to machine spindle

Quick Turn Smart 100M/2500M

Axial

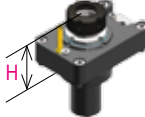

ER	Coolant	H	Nm	Rpm	ORDER CODE
32	Ext.	70	60	6000	99.MZ.A03
32	Int/Ext	70	60	6000	99.MZ.A06

Radial*

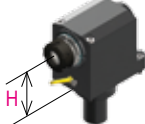

ER	Coolant	H	Nm	Rpm	ORDER CODE
32	Ext.	80	60	6000	99.MZ.A09
32	Int/Ext	80	60	6000	99.MZ.A10

*Direction of rotation opposite to machine spindle

BMT 45/55/65/75



Doosan - Hardinge - Samsung - Hwacheon - Hyundai WIA - Victor

Axial

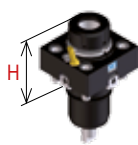

BMT	Coolant	ER	H	Nm	Rpm	ORDER CODE
45	Ext.	25	57.2	35	8000	99.DS.A03
	Int/Ext	25	57.2	35	8000	99.DS.A04
55	Ext.	25	52÷57.5	40	8000	99.DS.A01
	Int/Ext	25	52÷57.5	40	8000	99.DS.A02
65	Ext.	32	68÷72.5	70	6000	99.DS.A41
	Int/Ext	32	68÷72.5	70	6000	99.DS.A42
75	Ext.	40	90.1	100	6000	99.DS.A34
	Int/Ext	40	90.1	100	6000	99.DS.A35

Radial*



BMT	Coolant	ER	H	Nm	Rpm	ORDER CODE
45	Ext.	25	65	35	8000	99.DS.A07
	Int/Ext	25	65	35	8000	99.DS.A08
55	Ext.	25	70	40	8000	99.DS.A11
	Int/Ext	25	70	40	8000	99.DS.A12
65	Ext.	32	72	70	6000	99.DS.A51
	Int/Ext	32	72	70	6000	99.DS.A52
75	Ext.	40	112.1	100	6000	99.DS.A38
	Int/Ext	40	112.1	100	6000	99.DS.A39

*Direction of rotation opposite to machine spindle

Miyano

BMT 45 - ABX 51/64 TH2/TH3 - BNE 34/42 - BNJ 42/51
BMT 54 - ABX 51/64 THY - ABX 51/64 SYY

Axial

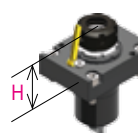

BMT	Coolant	ER	H	Nm	Rpm	ORDER CODE
45	Ext.	25	57.6	35	6000	99.MY.A02
	Int/Ext	25	57.6	35	6000	99.MY.A03
54	Ext.	32	79.4	60	6000	99.MY.A09
	Int/Ext	32	79.4	60	6000	99.MY.A10

Radial*

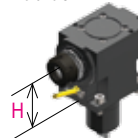

BMT	Coolant	ER	H	Nm	Rpm	ORDER CODE
45	Ext.	25	65	35	6000	99.MY.A05
	Int/Ext	25	65	35	6000	99.MY.A06
54	Ext.	32	93.9	60	6000	99.MY.A11
	Int/Ext	32	93.6	60	6000	99.MY.A12

*Direction of rotation opposite to machine spindle

Right Hand Radial Holder

DIN 69880 VDI B1



VDI	ORDER CODE
30	T.B1-30x20x40
40	T.B1-40x25x44
50	T.B1-50x32x55
60	T.B1-60x32x60

Right Hand Radial Holder*

DIN 69880 VDI B3



*Upside down

VDI	ORDER CODE
30	T.B3-30x20x40
40	T.B3-40x25x44
50	T.B3-50x32x55
60	T.B3-60x32x60

Multi-Seat Holder

DIN 69880 VDI D1



VDI	ORDER CODE
30	T.D1-30x20x60
40	T.D1-40x25x72
50	T.D1-50x32x85
60	T.D1-60x32x110

Left Hand Radial Holder

DIN 69880 VDI B2



VDI	ORDER CODE
30	T.B2-30x20x40
40	T.B2-40x25x44
50	T.B2-50x32x55
60	T.B2-60x32x60

Left Hand Radial Holder*

DIN 69880 VDI B4



*Upside down

VDI	ORDER CODE
30	T.B4-30x20x40
40	T.B4-40x25x44
50	T.B4-50x32x55
60	T.B4-60x32x60

Multi-Seat Holder

DIN 69880 VDI D2



*Upside down

VDI	ORDER CODE
30	T.D2-30x20x60
40	T.D2-40x25x72
50	T.D2-50x32x85
60	T.D2-60x32x110

VDI Blank

DIN 69880 VDI A1



VDI	ORDER CODE
30	T.A1-30x85
40	T.A1-40x100
50	T.A1-50x125
60	T.A1-60x160

Right Hand Axial Holder

DIN 69880 VDI C1



VDI	ORDER CODE
30	T.C1-30x20x70
40	T.C1-40x25x85
50	T.C1-50x32x100
60	T.C1-60x32x125

Left Hand Axial Holder

DIN 69880 VDI C2



VDI	ORDER CODE
30	T.C2-30x20x70
40	T.C2-40x25x85
50	T.C2-50x32x100
60	T.C2-60x32x125

VDI Blank

DIN 69880 VDI A2



VDI	ORDER CODE
30	T.A2-30x85
40	T.A2-40x100
50	T.A2-50x125
60	T.A2-60x160

Indexable Drill Holder

DIN 69880 VDI E1



*please specify diameter when ordering

VDI	Size Range	ORDER CODE
30	Ø16-40	T.E1-30x.....*
40	Ø16-50	T.E1-40x.....*
50	Ø16-50	T.E1-50x.....*
60	Ø16-50	T.E1-60x.....*

Boring Bar Holder

DIN 69880 VDI E2



*please specify diameter when ordering

VDI	Size Range	ORDER CODE
30	Ø6-40	T.E2-30x.....*
40	Ø6-50	T.E2-40x.....*
50	Ø8-50	T.E2-50x.....*
60	Ø16-50	T.E2-60x.....*



ER Collet Chuck

DIN 69880 VDI E4



VDI	ER	ORDER CODE
30	16	T.E4-3016
30	25	T.E4-3025
30	32	T.E4-3032
30	40	T.E4-3040
40	25	T.E4-4025
40	32	T.E4-4032
40	40	T.E4-4040
50	25	T.E4-5025
50	32	T.E4-5032
50	40	T.E4-5040
60	32	T.E4-6032
60	40	T.E4-6040

Morse Taper Chuck

DIN 69880 VDI F



VDI	Morse Taper	ORDER CODE
30	1	T.VDI30MK1
30	2	T.VDI30MK2
30	3	T.VDI30MK3
40	1	T.VDI40MK1
40	2	T.VDI40MK2
40	3	T.VDI40MK3
40	4	T.VDI40MK4
50	2	T.VDI50MK2
50	3	T.VDI50MK3
50	4	T.VDI50MK4
50	5	T.VDI50MK5
60	2	T.VDI60MK2
60	3	T.VDI60MK3
60	4	T.VDI60MK4
60	5	T.VDI60MK5

Tension & Compression Tap Chuck

DIN 69880 VDI GML



VDI	Adaptor Size	ORDER CODE
30	1	T.VDI30GR1
30	2	T.VDI30GR2
40	1	T.VDI40GR1
40	2	T.VDI40GR2

Right Hand Part Off Holder

DIN 69880 VDI AR



VDI	Blade	ORDER CODE
30	26	T.AR-3026
30	32	T.AR-3032
40	26	T.AR-4026
40	32	T.AR-4032

Right Hand Part Off Holder*

DIN 69880 VDI ARU



*Upside down

VDI	Blade	ORDER CODE
30	26	T.ARU-3026
30	32	T.ARU-3032
40	26	T.ARU-4026
40	32	T.ARU-4032

Left Hand Part Off Holder*

DIN 69880 VDI AL



*Upside down

VDI	Size Range	ORDER CODE
30	26	T.AL-3026
30	32	T.AL-3032
40	26	T.AL-4026
40	32	T.AL-4032



1	Shank tolerance IT6 (H6)
2	Hardened to HRc58 all over
3	Internal diameters, shank and teeth completely ground finish

Bar Puller

DIN 69880 VDI SG



VDI	ORDER CODE
30	T.VDI30-BP10-75
40	T.VDI40-BP10-75
50	T.VDI50-BP10-75

VDI Steel Turret Cap

DIN 69880 VDI



VDI	ORDER CODE
30	T.VDI 30 - AC
40	T.VDI 40 - AC
50	T.VDI 50 - AC
60	T.VDI 60 - AC

VDI Plastic Turret Cap

DIN 69880 VDI



VDI	ORDER CODE
30	T.VDI 30 - PL
40	T.VDI 40 - PL
50	T.VDI 50 - PL
60	T.VDI 60 - PL



GERARDI **FOCUS**

Bespoke Workholding

Bespoke Design

Because of Gerardi's huge range of standard parts, bespoke work holding solutions can be designed quickly, usually within 48 hours. Designs can be tailored to suit any machine tool and budget with different options for the end user.

Bespoke Manufacturing

All Gerardi bespoke workholding comes with the same quality and precision of the standard ranges including 20 microns ground working surfaces, jaws/bases hardened to HRC60 and a 5 year warranty.

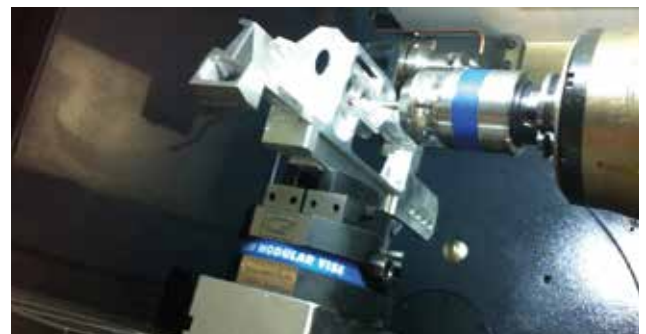
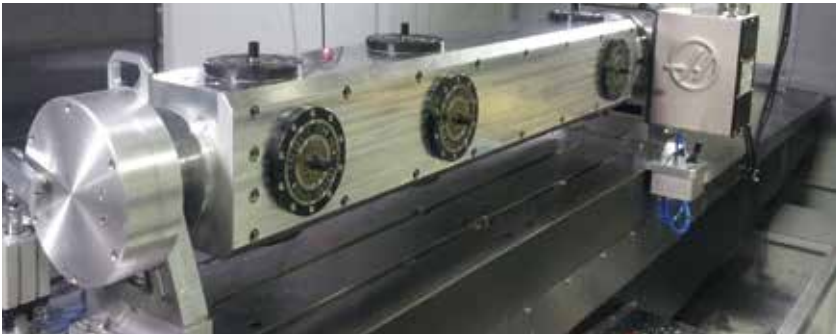

GERARDI SPA

via Giovanni XXIII, 101
21015 LONATE POZZOLO (VA) Italia
Tel. +39.0331.303911 - Fax +39.0331.301534

gerardi@gerardispa.com
www.gerardi.it

Distributed by: